



From The Idea To The Product: Concept-Led Printing

Creation | Print | Binding

Prinovis

Our Production Concept at a Glance ...

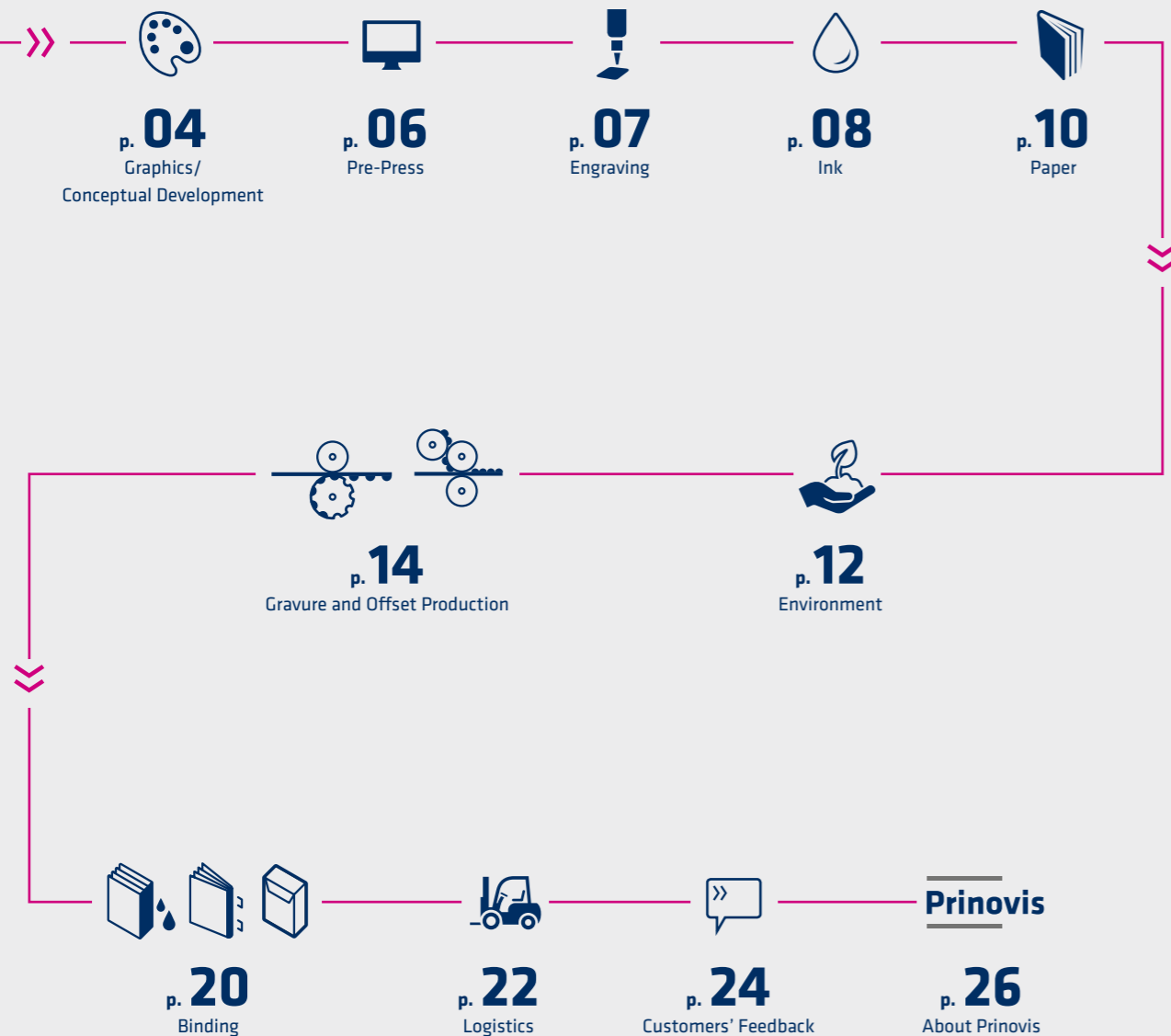

Ladies and Gentlemen,

Dear Customers and Partners,

Prinovis is the largest provider of printing services in Europe, with four printing sites in Germany and in Great Britain.

We offer you a wide-ranging portfolio of solutions – ranging from conceptual development and creative inputs, through gravure print and offset print, and including binding and logistics. Our strength is based on our highly-committed workforce's many years of experience. This is reinforced both by our owner and shareholder Bertelsmann and also by our partner companies within the Bertelsmann Printing Group. It is a strength that enables our company to declare its commitment to developing and implementing innovative and high-quality services and products.

Individual customer care is one of our most important goals: in this context, we see our role as that of the primary contact; we give you comprehensive advice in finding the best possible solution to match your profile of needs.

»Creating the highest quality and flexibility for you, our customers - that is the challenge we set ourselves each day.«

Astrid Meicherzyk | Executive Director - Prinovis

As for specifically what Prinovis does as a printing-services-provider, how the work is carried out and which made-to-measure solutions are put into place for customers such as you – it is our aim to give you a first impression of this on the following pages. I hope that you will find it to be an entertaining and informative read.

Sincere best wishes to you.

Yours, Astrid Meicherzyk

Promotional Skill - the Creative Kick-Off

MBS Nürnberg GmbH, as a one-hundred-per cent subsidiary of Prinovis, is at the service of Prinovis's customers when the topics are promotional photography and design. As your partner for perception-related and visualisation-related product aspects, we currently offer you three activity areas in one company: agency services, photography and e-commerce services from a single source.

MBS is your partner for successful brand communication. The reason is that our agency perfectly masters cross-media communication – whether it is classic promotional material and corporate design or campaigns in print, on radio and TV, or on the web. Our portfolio is also made all the more attractive by our digital solutions, with apps, e-magazines or mobile web design – all of which have now become indispensable success factors.

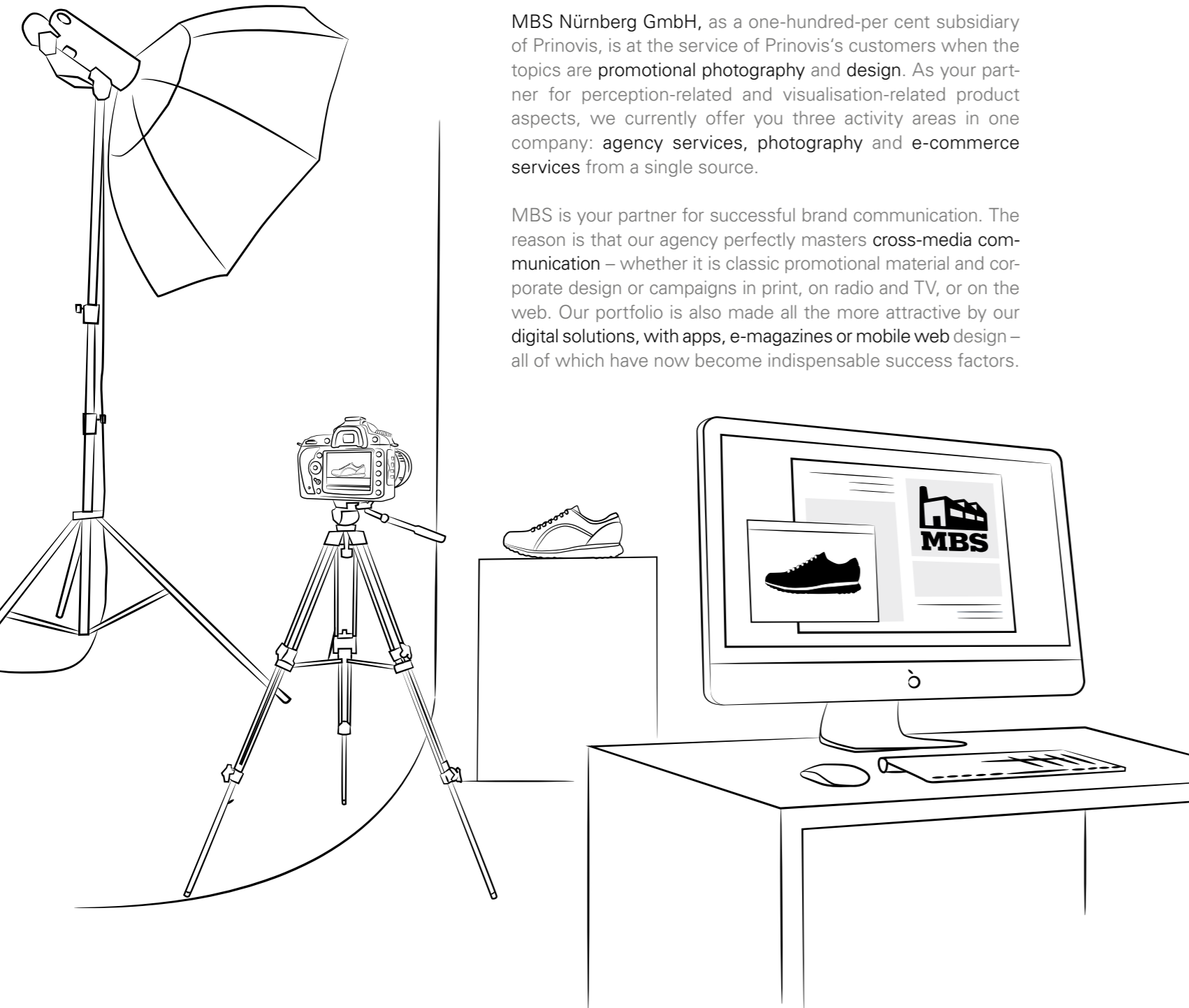

»» From the conceptual work and creative development, via photography and through to e-commerce services – our unique combination provides key benefits for you. ««

Marcus Modsching | First Managing Director - MBS

Likewise, on the topic of photo-shoots for fashion, interiors, jewellery or food, be it for print or for the web, we always focus on one thing – your brand. That is why MBS offers you the perfect stage for presenting your products in the best possible light – in 12 studios, at more than 25 dedicated photo-shoot sets, and worldwide on location. The whole organising process is taken over by our highly-competent project-management team.

This outstanding interplay of the teams involved enables us to produce high-calibre content for you. In a highly-professional and dedicated way, we combine inputs from all activity areas; this enables us to produce more than 1,000 photos per day. As a result, your e-shop is set up with the pictures and article-texts that it needs, within 48 hours.

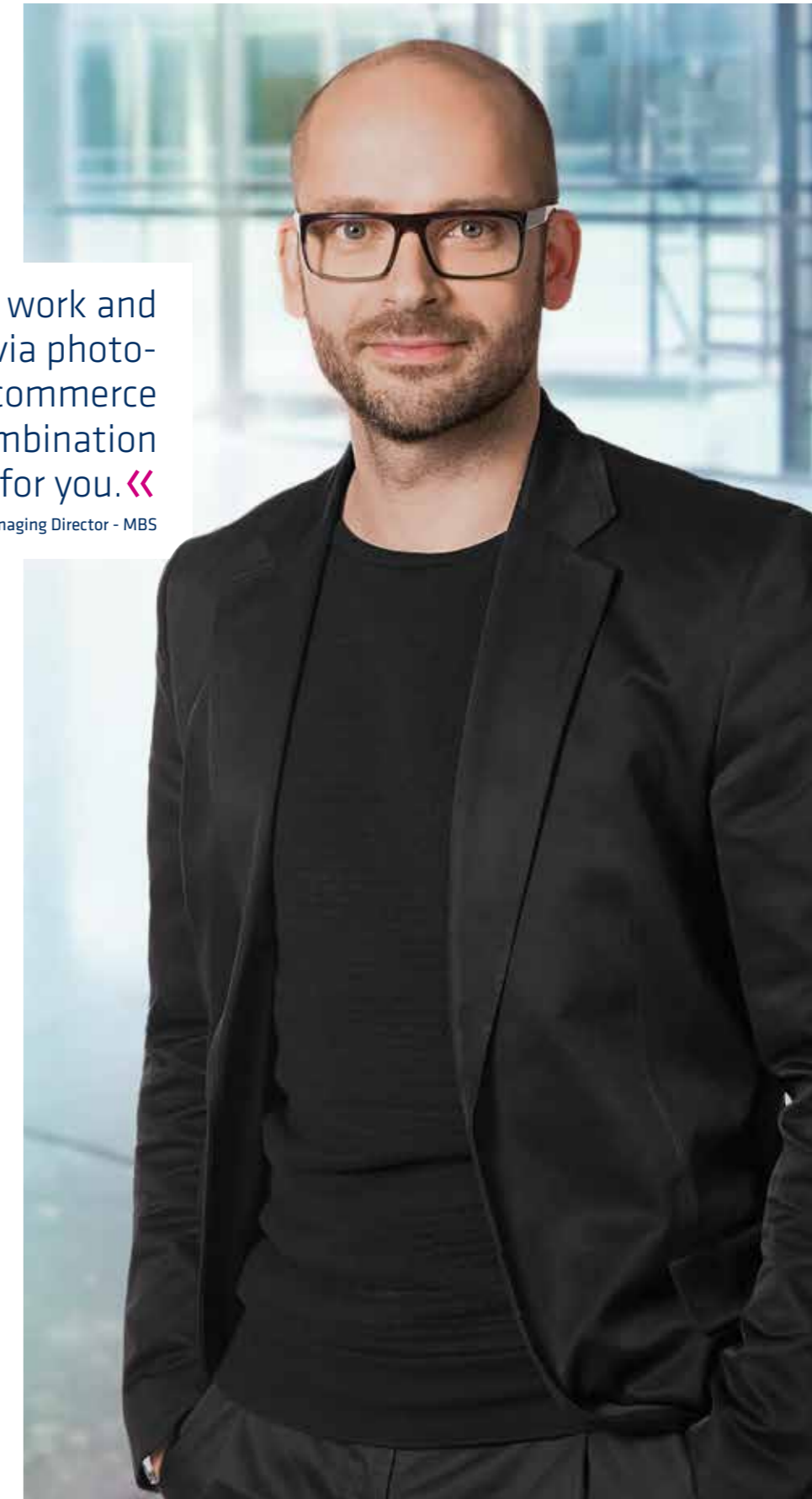

Soft-Proofs: the Reliable Foundation

An end to digital paper-proofs and paper-costs, as well as transportation-costs for proofs – Prinovis's **flexible digital soft-proof procedure** makes this possible. This process is specifically coordinated to match your needs. As early as the stage at which data is received and processed in pre-press, we can use the **monitor** to make a **binding assessment** of the print-result that follows, with regard to the **colour-reproduction**. This way, unwanted surprises – such as imprecise logo-colours that are inconsistent with the corporate design, or skin tones not matching those intended – are made into a thing of the past.

To fully match the highly exacting standards of gravure print, you as the customer are given an opportunity to use the soft-proof to make a binding clearance of the pages' visual presentation for print (**also in terms of the colours**); this is done immediately after the page is produced and, where appropriate, you can make **corrections straightaway**.

Standardised workflow systems and their use on all our print machines guarantee **quality consistency as well as colour-accuracy**; also, everyone involved saves extra days spent on this task.



Impressive Made- to-Measure Start

»Our automated cylinder production stands for highest quality, flexibility and efficiency.«

Reiner Hoheisel | Production Planner on Pre-Press Operations - Prinovis Ahrensburg

Up to 6,400 print-cylinders in various sizes, ranging from the smallest width (at 2120 mm) up to the largest (at 4400 mm), are at the ready on the Prinovis sites to be engraved for you straightaway. Accordingly, we can produce not only continuously and with the **smallest possible level of cut-off**, but also produce versions quickly and flexibly.

This is a bonus for our environment and also for your bottom line: time is money. Not least for this reason, our engraving and galvanising process is operated by our work-traffic management system. The latter is **fully automated** for the copper production and chrome production. We use Callguard 3 on all facilities. This ensures the highest levels of engraving quality.



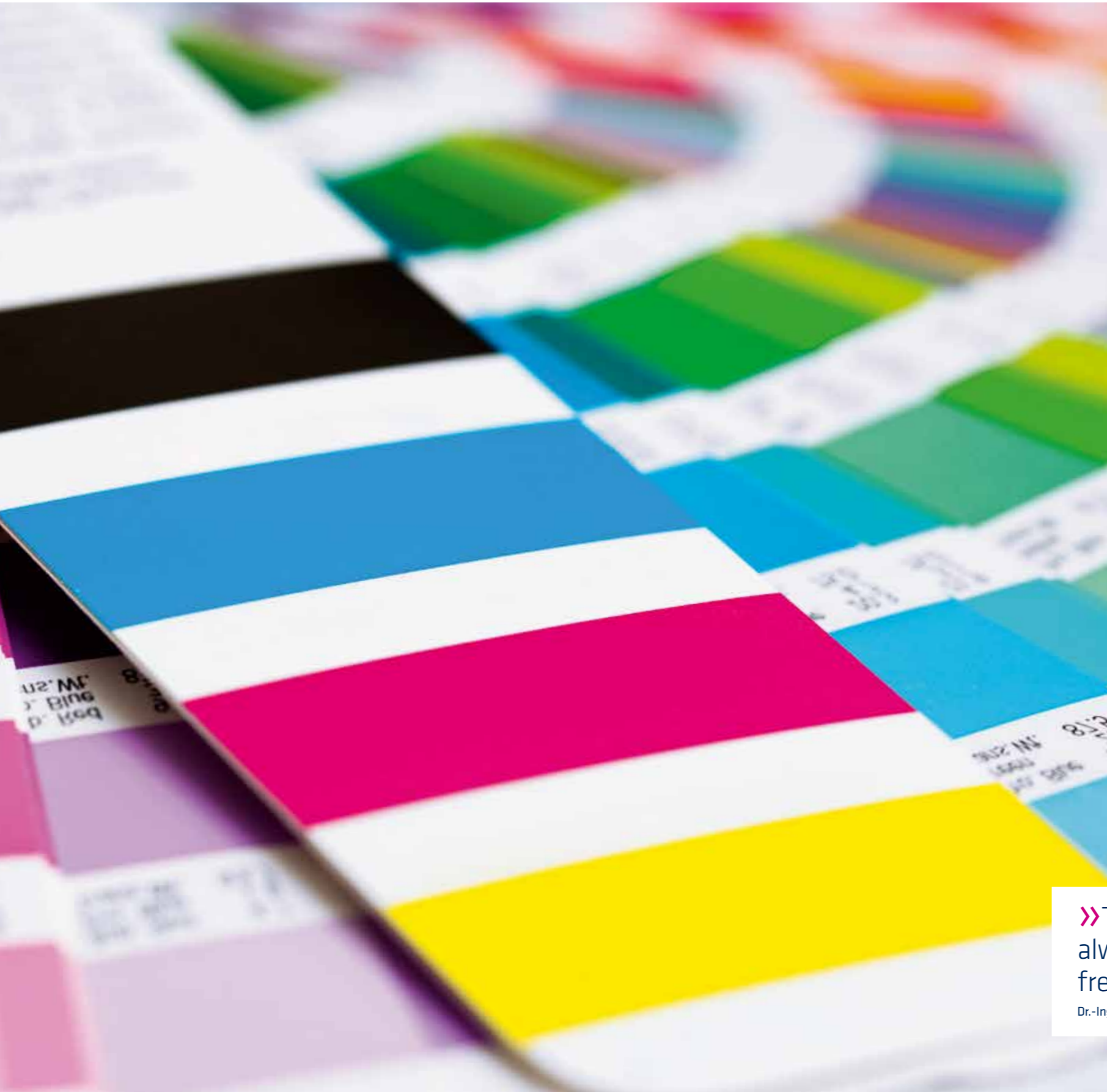

Placing Ink with Pin-Point Precision

Daily ink-checks in our in-house laboratories guarantee you a consistently high level of print quality – whichever production site is used. Under Prinovis's leadership, industry-wide colour-standards were developed across the gravure industry. This ensures very good colour quality in the so-critical grey area and skin-tone area respectively, for example. This guarantees a high precision of colour management throughout the whole colour spectrum, for each paper-type, covering the range from the initial proof through to the final print. This is offered in large print-runs as in small ones, of course.

And if you are looking for something particularly distinctive, we provide you with high-calibre refinements, using special inks and UV varnish. In a similar vein, our portfolio of services includes workshops on ink and product training on assessment both of ink and of the printed product. As a point of principle, we provide customer-support to you in the context of solutions to problems in the daily business, for instance with subject-specialist reports and made-to-measure analyses.



»The ink that you wish to get always remains identical – no matter how frequently we print a particular page.«

Dr.-Ing. Claudia Jahn-Wolf | Head of the Central Quality and Process-Control Facility - Prinovis

Specialist Expertise Puts Us in the Lead

Derive benefit from our many years of experience and extensive subject knowledge of paper and print-industry processes. These strengths guarantee you highly-competent advice and reliability in the process of evaluating print-products. As a dependable partner of the paper industry – in product development and testing – we provide you with support, both with the selection of paper and also

in its use in an efficient way that meets quality-related requirements. Combining paper in a professional way guarantees benchmark advantages. Focus on the paper-user's tactile experience - for instance, combine high-gloss gravure paper on the cover with bulky, matt offset paper in the inner sections.

Certified and equipped both with innovative and also with conventional testing technology, our highly-specialised department for this subject-area employs its tried-and-tested working practices – as well as unusual ideas, when called for; its task in this is to contribute to enabling greater efficiency to be achieved by customers and suppliers.

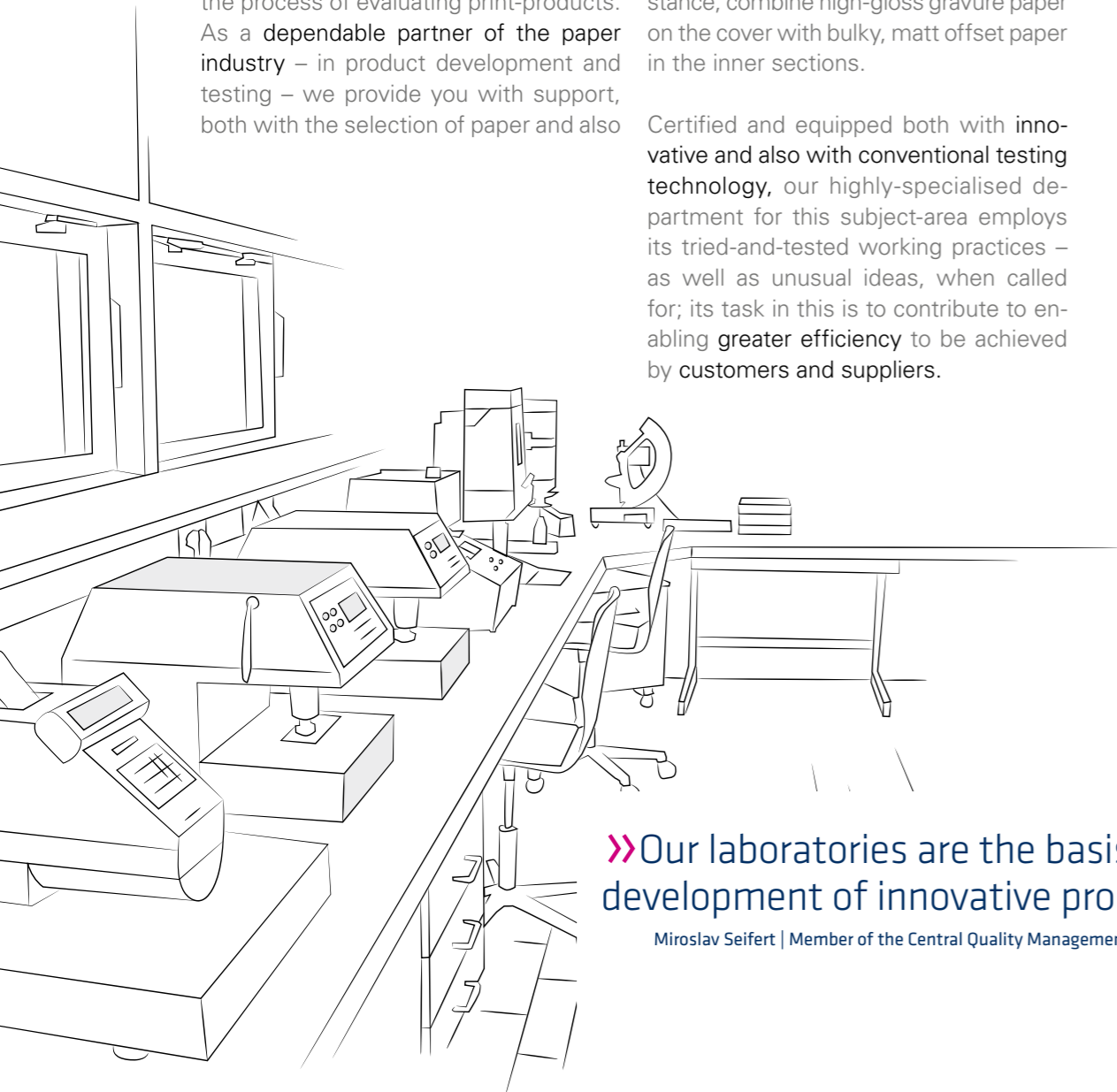

»» Our laboratories are the basis for the development of innovative products. ««

Miroslav Seifert | Member of the Central Quality Management Team - Prinovis

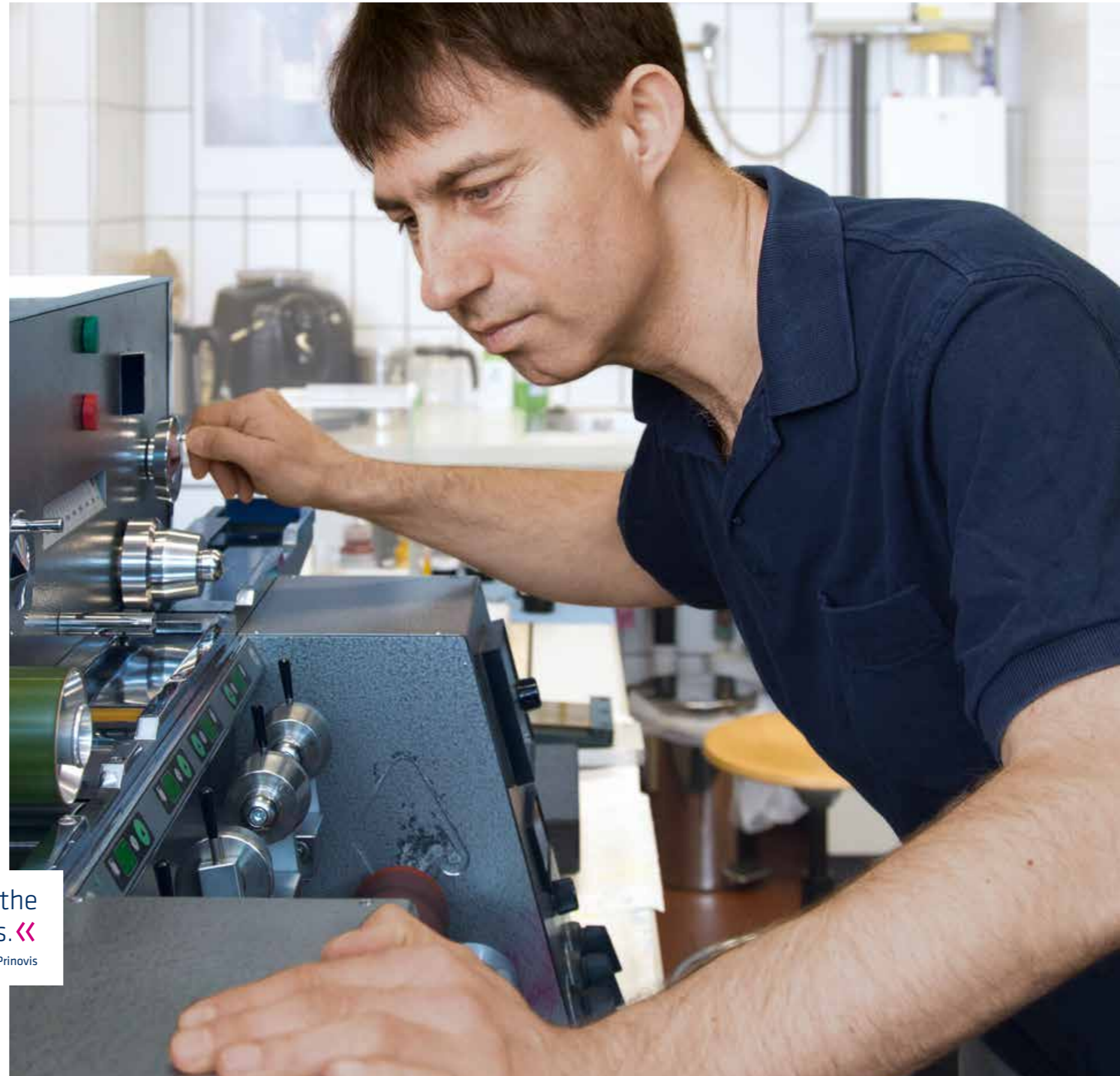



We Create Transparency

We explicitly commit ourselves to the **responsibility to society and to the environment** that the manufacture of print products involves. So as to fully meet this responsibility, we are operating an **active environmental and energy policy**.

Thus, for instance, in recent years we have continuously raised the proportion of certified paper used - its share of the total currently already comprises around 40%. The **multi-site FSC®** and **PEFC™** certificates guarantee the use of papers for which the wood originates from sources employing responsible forestry-management practices. As of the spring of 2016, Prinovis is solely buying-in paper that has FSC or PEFC certification respectively. This applies to all consignments of paper which we buy ourselves.

Beyond this, **certified energy-management** supports Prinovis in using energy with optimum efficiency. The establishment of an environmentally-friendly combined heat-and-power generation facility at the Dresden site means that around 800 tonnes of CO₂ emissions are avoided each year. In addition, our offset machines print without use of isopropyl alcohol in the moisturising unit; similarly, at our sites toluene – a solvent specific to gravure-printing – gets 99.8% recycled.

Because we know exactly how the processes work, we filter everything from our waste-water that could endanger the environment. By raising the ratio of total inputs that is recycled and re-used, we continually reduce the proportion of waste.



The mark of responsible forestry



PEFC/04-31-0917

Promoting Sustainable Forest Management
www.pefc.org

»» Across all our sites, our environmental team ensures responsible environmental management. ««

Christine Uhde-Leischner | Company Specialist FSC®/PEFC™ - Prinovis



The best, multifaceted solution - always!

So you need a large print-run or print-material with a high page-count? We offer you the optimum production possibilities, with first-class quality printing. The Prinovis process standard always guarantees consistently high quality. Thanks to our speed in the make-ready and version-changing process, our optimum lead-times mean real benefits for you.

Our great diversity of machines at the various sites enhances the flexibility offered to our customers, opening up multifaceted options to meet the production needs.

Apart from this, we offer you services such as producing print-dummies and consultation on paper, ink, and the format of the printed product. This is in addition to the refinement of the wide-ranging product spectrum using special inks or special varnishes.

»»The number of sites we have, with our diversity of machines, makes us particularly flexible in matching customers' wishes.««

Dirk Lange | Member of the Press Team - Prinovis Ahrensburg

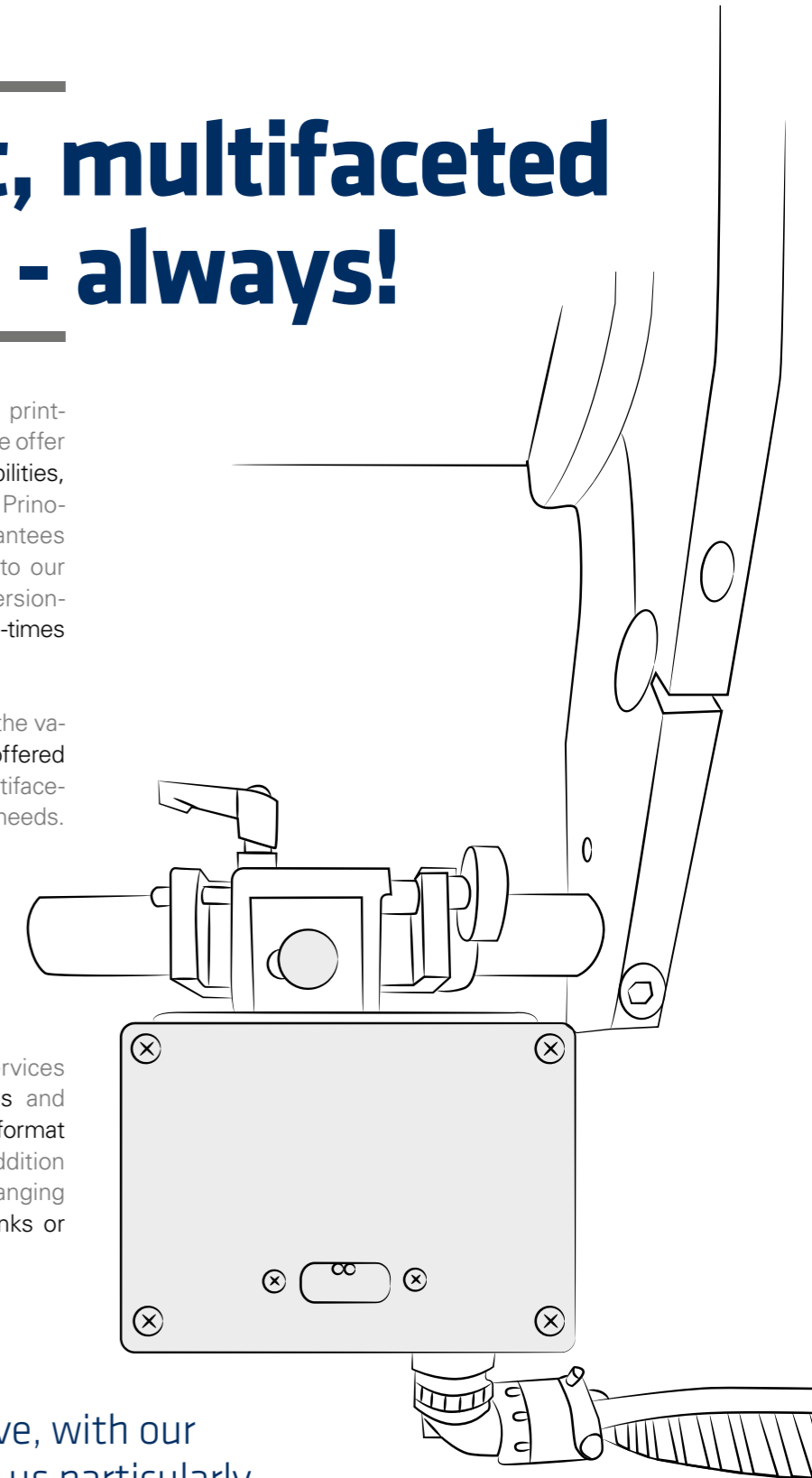

Offset and Gravure Printing at One Site

As the first printing house in Germany to do so, Prinovis's Dresden site is offering offset print from two presses as well as its gravure-print core business. Print assignments involving the most diverse range of print-run sizes, as well as high-calibre combination-printed brochures, can be produced efficiently and flexibly, without involving long journeys between sites. As a result, all the more exacting customer requirements can be met as regards print-run-size, regionalisation, quantity adjustments at short notice, as well as different language versions. As part of this, we optimise the print-data supplied and adapt these inputs to the print procedure that is selected.

Together with you, we have the opportunity to select the ideal procedure for your print order. Your advantages are:

- » **Diversity of paper:** Enhance the end-user's tactile experience, combining glossy gravure-printed paper with bulky, matt offset-type paper.
- » **Diversity of print-product formats:** Alongside the regular formats used, you can provide special pocket-editions in implementing your printed product.
- » **Time-saving:** We guarantee that you save time because of a process coordinated with you, e.g. for publishers, advertising customers and insert-using customers.
- » **Logistics advantages:** Lower freight costs through the combined dispatch of a variety of printed products, as well as a reduced number of intermediate transportation consignments.

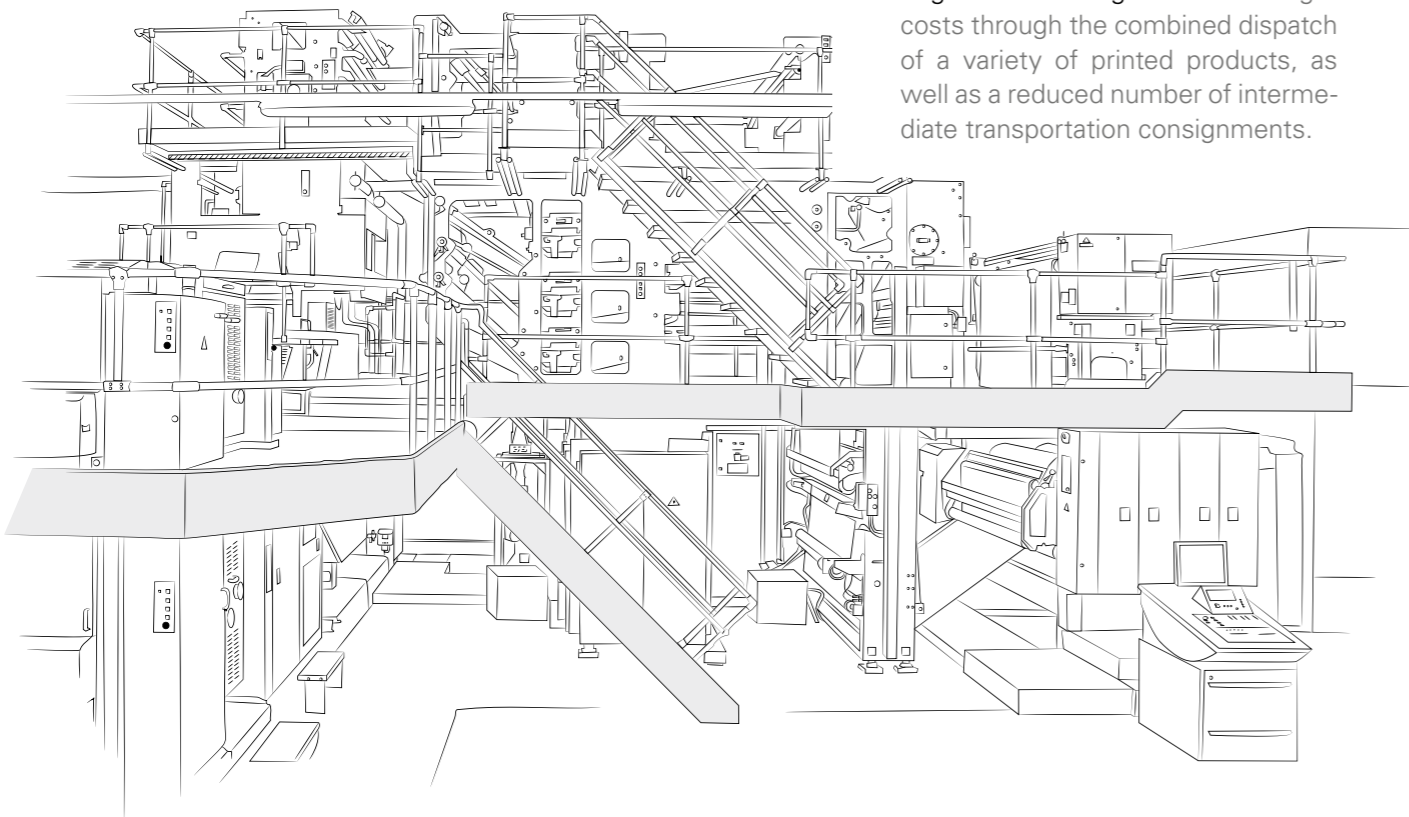



Quality - proof of outstanding competence!

Even during the preliminary selection of the offset papers and print-inks, we influence our products by assessing the materials in an economically-viable, quality-focussed way; this supports the purchasing and production departments in their tasks. It is very important to us to adapt the selection to the desired product portfolio in the optimum way. Our in-house, certified laboratories for paper, print-ink and the print process make this possible. These elements serve as the guarantee of consistently high print-quality.

We even offer our customers made-to-measure training courses about paper, ink and printing processes, and also on the investigation of causes if printing is disrupted. We also make available appropriately rigorous expert reports with regard to paper and to print products. Accordingly, any claims of sub-optimum performance can undergo an objective assessment, saving time and money. All recommendations in these reports are readily comprehensible, kept close to actual practice and checked to ensure that they can realistically be implemented.

The market's high level of acceptance of these services results from our close interaction with supplier industries; it also makes us the No. 1 organisation to contact in terms of the technical aspects of paper and ink.

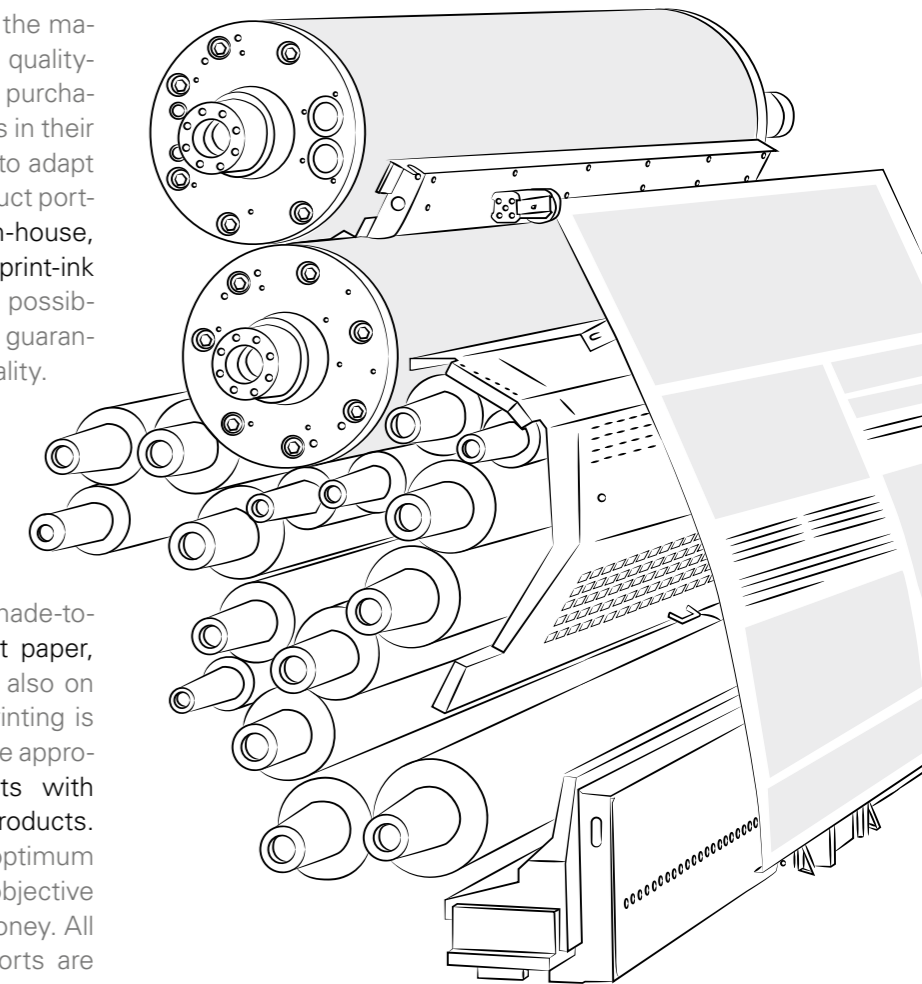

The Ideal Extra Element to Boost Income

Whether it is perfect binding, saddle-stitching or polybagging – the **extensive range of binding methods** used by Prinovis open up the possibility of **very high machine-speeds**. So as to boost end-customers' impulse purchases and your turnover, we are able to process bound inserts, loose inserts and glued inserts, as well as ad-specials – the latter are highly effective in promotional terms (product samples, shrink-wrapped bundles with top sheet, packing cards, booklets on the cover, etc.).

Hybrid production is proving to be particularly cost-competitive: in this, offset

and gravure items of content respectively are bound without interim stages of transportation. Also, in the event that printed sections are to be produced only at a later stage in the process, our sophisticated storage-management operations come into play. It is our pleasure to assist you with our expertise in providing advice on this; we also offer you test-production processes for the flexible implementation of special wishes.

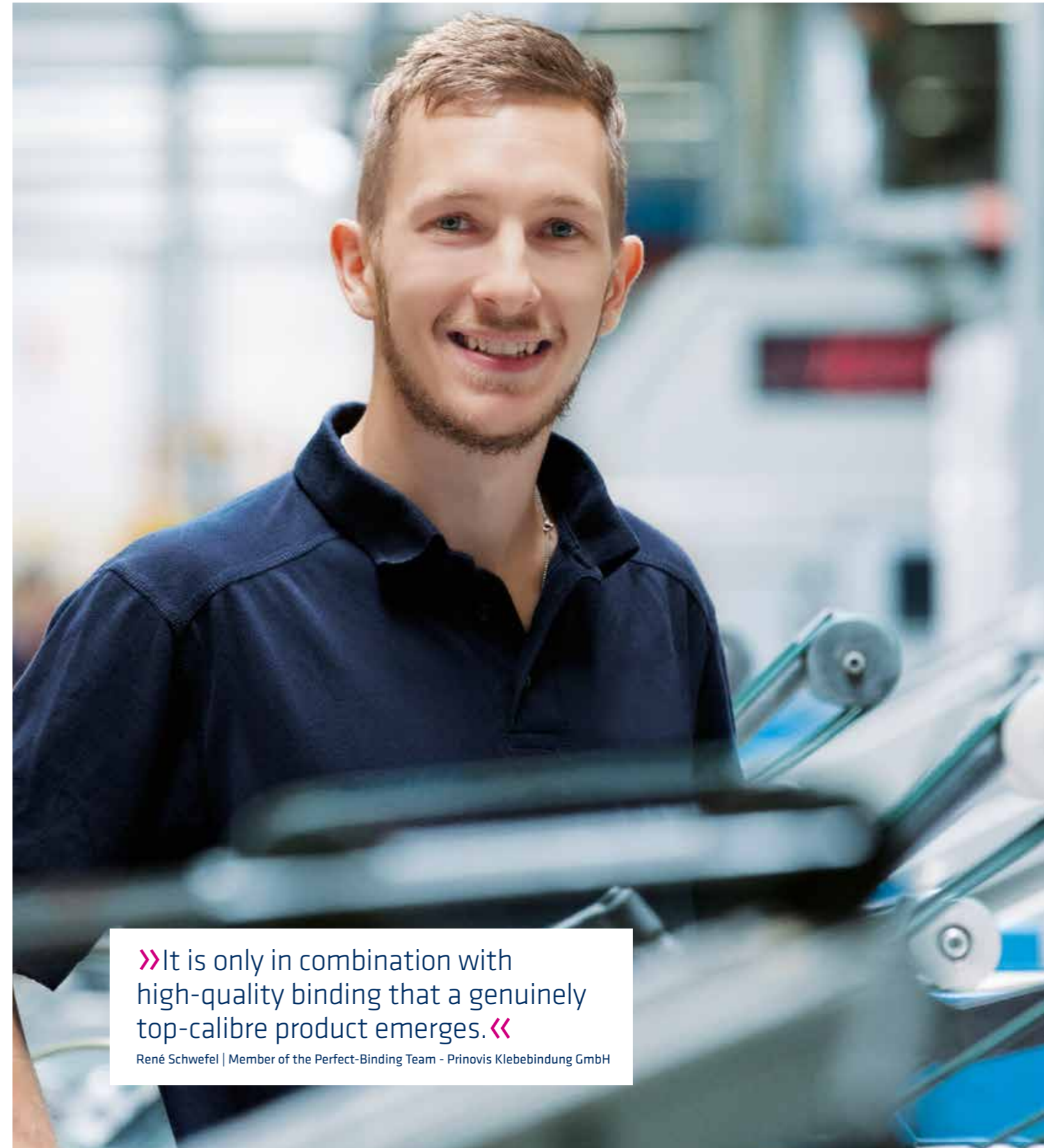
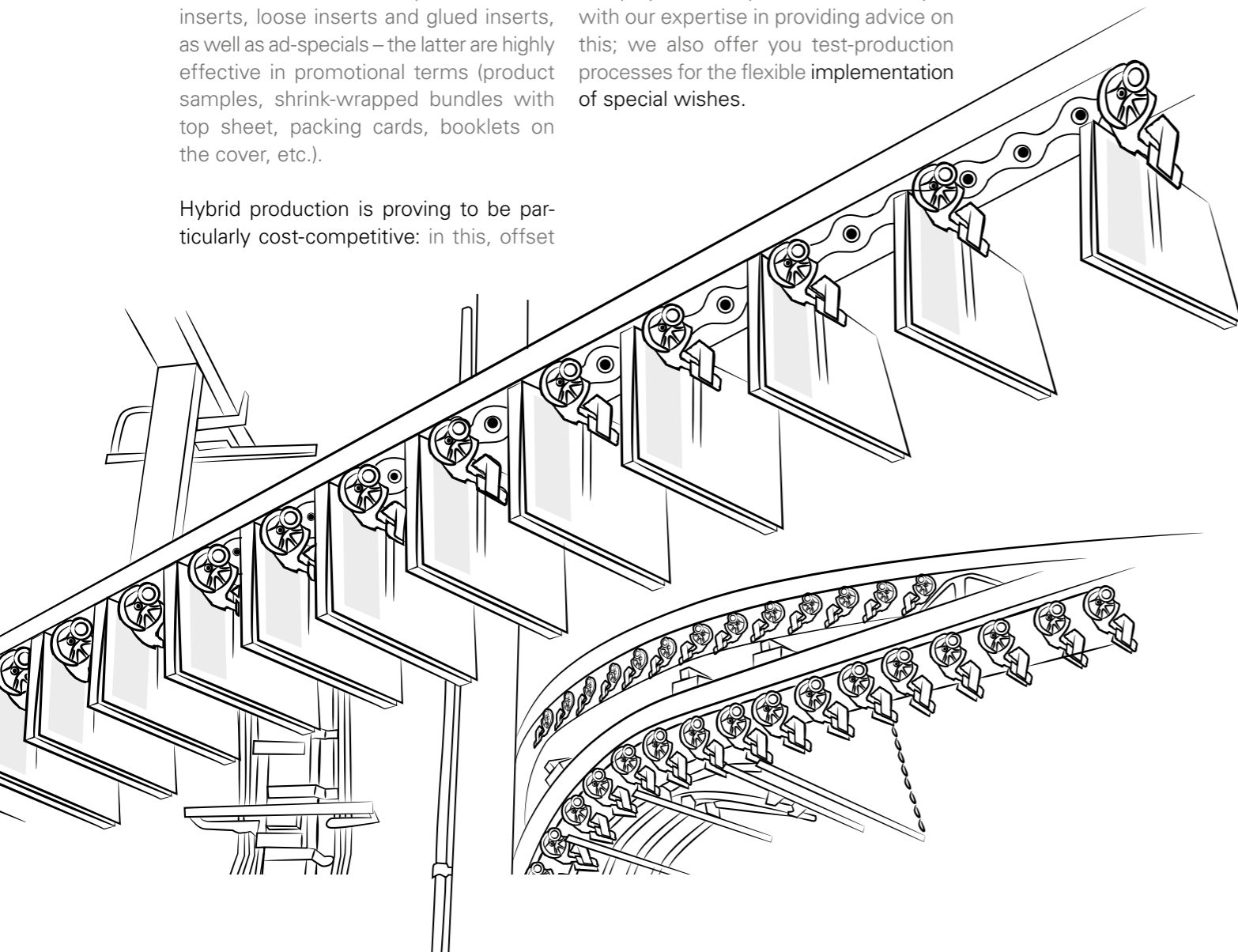

» It is only in combination with high-quality binding that a genuinely top-calibre product emerges. «

René Schwefel | Member of the Perfect-Binding Team - Prinovis Klebebindung GmbH



Your Network for the Optimum Final Run

Certified as an acknowledged dispatch partner, our logistics experts manage a diverse range of national and international dispatch solutions; naturally, these also include air-freight or sea-freight, as well as customs-handling at the destination. As your reliable partner for logistics solutions designed to match needs, Prinovis offers a high-performance service.

Our professional data-management is also at your disposal – this includes registration and analysis of addresses respectively, checking for duplication, and also updates and layout-programming. If you wish to send individual items on a combined basis, our existing logistics network offers you lots of options, both for this and for just-in-time delivery, by means of detailed pre-production planning.

We achieve savings on the transportation costs. Our company's attractiveness in the market, evident in high purchasing-volume, dispatch consignments pre-sorted by post code, and the GPS-based monitoring of our lorries, contributes to the minimisation of costs for you.

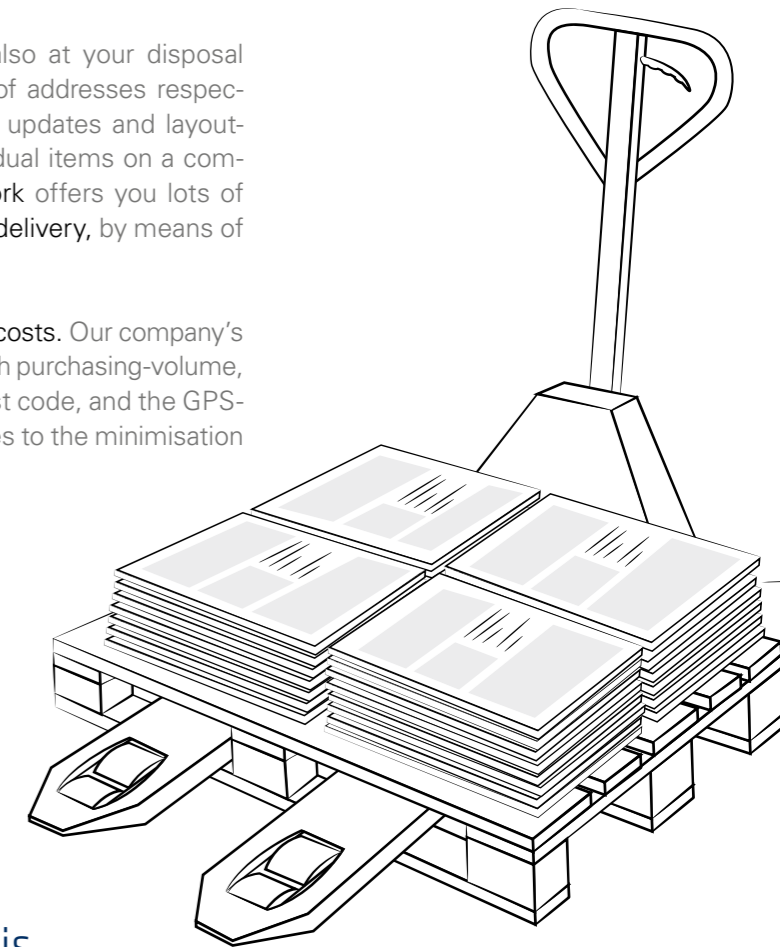
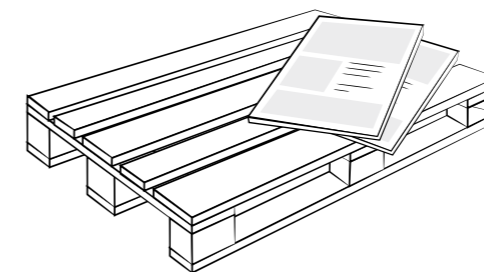

»As a reliable partner, Prinovis is characterised by a high level of dynamism and by outstanding dispatch logistics.«

Tatjana Springer | Member of the Order Management and Freight Purchasing - Team Prinovis Nuremberg

Satisfied Customers

Robert Köhler
Head of Marketing
Communications
Bauhaus

»Starting from a first concept, through photography, to the final design, and then moving on to print and delivery of the finished products, the Prinovis team works fast and reliably and, above all, with excellent commitment.«

Britta Körner
Head of Department
Graphics & Production
Dänisches Bettenlager

»We have high expectations, in terms of flexibility and speed, when it comes to production of our promotional material. In this environment, Prinovis has consistently proved its worth as a reliable and service-oriented partner, one that supplies top quality and regularly goes beyond what standard requirements dictate.«

Lars Reinecke
Production Director
Conde Nast Verlag

»Our trust-based partnership with Prinovis spans many years. Printing 'GLAMOUR' demands highly-competent advice, reliable customer-care, adherence to deadlines, and security of production. We also need consistently high quality in the printing and the binding. Prinovis meets all these needs.«

Christian Kitzmüller
Head of
Production/Electronic
Image Processing
Wort & Bild

»The 'Apotheken Umschau' is printed in a very high quantity and consists of very many versions. Prinovis manages this challenge impeccably and always produces the periodical on time and in high quality.«

Rüdiger Dienst
Chief Executive Officer
Mediengruppe KLAMBT

»Prinovis and the KLAMBT media group look back on a partnership-based cooperation that by now spans many years; it is always shaped by the shared goal of attaining competitive advantages in a discerning and volatile market. In the future, as now, the supporting pillars in this will remain flexibility, trust and willingness to innovate.«

Jens Müller
Head of Production
Motor Presse Stuttgart

»The quality of our printed products is our primary concern. The printing process cannot be a factor that influences that requirement. Yet having said that, it's a delight to see how quickly and smoothly the switchover of our motorcycle magazine MOTORRAD from gravure to offset has been successfully managed.«



BAUHAUS

G+J

FUNKE
MEDIEN
GRUPPE

OTTO

MÖBEL
KRAFT

MEDIENGRUPPE
KLAMBT

motor
presse
stuttgart

WORT
& BILD
VERLAG

FUNKE
ZEITSCHRIFTEN

CONDÉ NAST VERLAG

Prinovis at a Glance

»As Europe's leading printing group, we offer you a whole spectrum of services based around our core competence – printing – as well as in the areas of binding, creative development in a media context, and digital solutions.«

Part of the Bertelsmann Printing Group



Liverpool



Ahrensburg



Gütersloh



Dresden



Nuremberg

4 printing sites

in addition to the Group headquarters in Gütersloh.



2,200 employees*

Portfolio Creative Development:



ADVERTISING AGENCY



PHOTOGRAPHY



E-COMMERCE SERVICES

Portfolio Print:

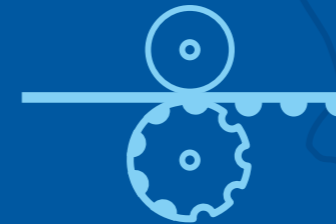

GRAVURE PRODUCTION

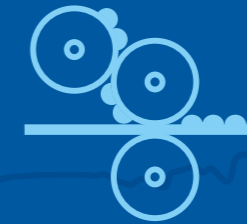

OFFSET PRODUCTION

Portfolio Binding:



PERFECT BINDING



SADDLE-STITCHING



POLYBAGGING

28,808 km²

VOLUME OF PRINTED PAPER PRODUCED EACH YEAR*

Customer structure:*

25%

RETAIL AND OTHER CHANNELS

45%

PUBLISHERS

30%

MAIL-ORDER COMPANIES

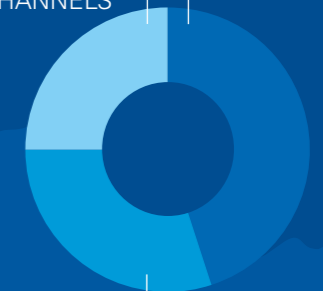

IMPRINT

Print | Offset:
Osterchrist druck und medien GmbH
Cover:
200 g/m² | picture print matt dispersion coating satin finished + partial gloss UV coating
Content:
135 g/m² | picture print matt dispersion coating satin finished
Conceptual development and design:
MBS Nürnberg GmbH
Editorial:
Prinovis GmbH & Co. KG
MBS Nürnberg GmbH
Photos:
Klaus Knuffmann, Sven Berger, MBS Nürnberg GmbH

*relates to the year 2015



www.prinovis.com

Prinovis GmbH & Co. KG
Tel.: +49 (0) 911 - 8003 0
kontakt@prinovis.com
