

Storage

PRODUCT INFORMATION



ASSMANN

Contents

Allvia	4
--------	----------

Cubas	18
-------	-----------

Intavis	26
---------	-----------

Pontis	32
--------	-----------

Dekore	41
--------	-----------

Allvia



Allvia is a versatile storage space system for variable interior designs. With its large selection of free-standing, wall-aligned or partitioning cabinet configurations, the Allvia range delivers a suitable furnishing solution for every requirement.



Learn more
<https://ass.al/nvgnhv1>

Beyond tidy

Everything has its right place in the Allvia storage space system, whether it's important work documents or personal items. Optional sound absorption can also be guaranteed by integrating the acoustically effective Viteco partitioning screen system on the Allvia cabinets.



Versatile storage space concept

The Allvia storage space system comes with a wide variety of base designs.

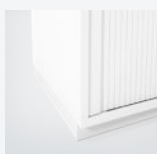

Steel base
Height:
40 mm

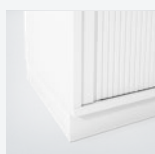

Steel base
Height:
70 mm



Lower frame with rectangular legs
Height:
150 mm



Lower frame with round legs
Height:
150 mm



Telescope steel base
Height:
70 mm



For different use cases

With its wide range of individual combination options, Allvia offers extensive storage space solutions for office workstations, conference rooms or when working from home.



Sliding door cabinet: Everything right on hand at the workplace



Wing door cabinet: Sufficient space for archiving

Eye-catcher in every office

A plant pot mount can be added to the Allvia storage space system to create a pleasant and cosy atmosphere. The plant pot mount is available with plastic or pine bark inserts and with different varieties of artificial plants.



Artificial plants

A variety of artificial plants are available for the Allvia plant pot mounts.

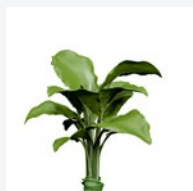

Alocasia Calidora

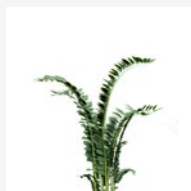

Zamioculcas

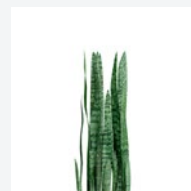

Sanseveria



Bamboo grass



Versatile storage space concept

Allvia enables extensive design and configuration options for combination and upright cabinets. Customers have a large choice of cabinet models in a wide variety of heights and widths.



High-quality materials: Writeable crystal fronts



Combination cabinets: For attractive interior design

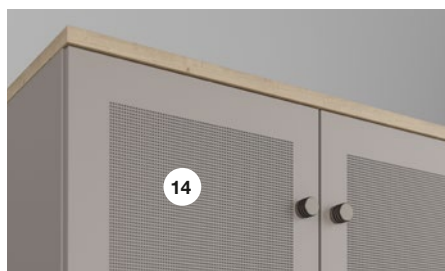
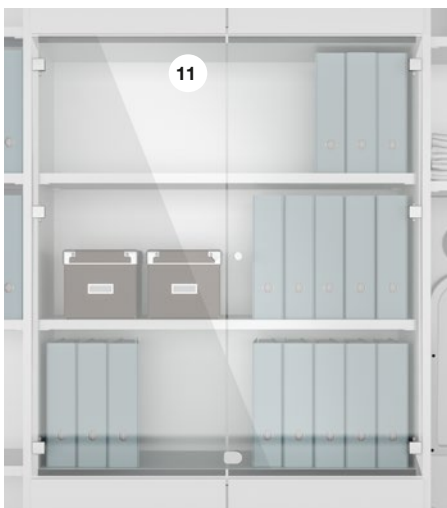
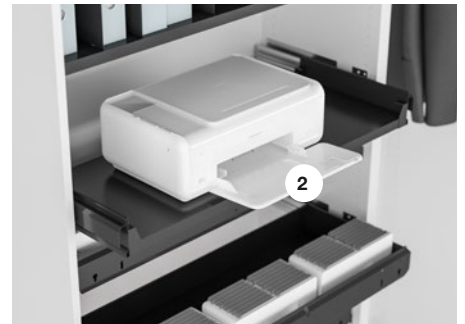
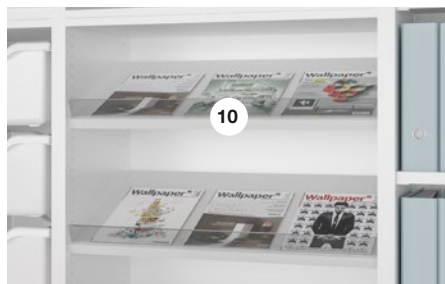
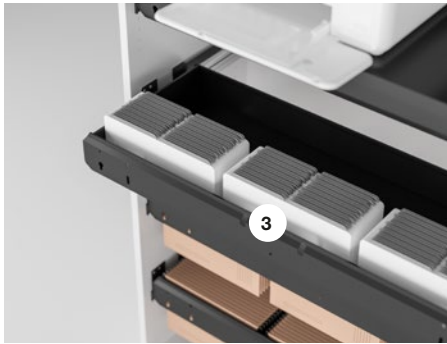
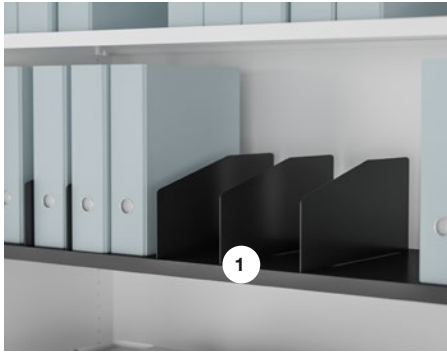

Matching accessories for individual equipment

With extensive accessories and a wide range of equipment variants, the Allvia cabinet systems can be upgraded and extended individually to suit any need.

① **Folder supports**

② **Pull-out shelves to accommodate office equipment**

③ **Wide drawers with index card racks**

④ **Suspended filing frame or drawers for installation behind the doors**

⑤ **Pull-out wardrobe (also available as a coat rack)**

⑥ **Suspended folder rail for the Zippel or Elba system**

⑦ **Steel strongbox**

⑧ **Orgaboxes**

⑨ **Pull-out tray**

⑩ **Prospectus shelves**

⑪ **Frameless glass door**

⑫ **Cleaning supplies cabinet**

⑬ **Drawer**

Acoustically-effective surfaces

⑭ All fronts are available with an acoustically effective surface and an exposed back wall in absorbent fabric and different colours for free-standing sliding or tambour door units.

Fabric back wall

⑮ An exposed back wall in absorbent fabric is available in a variety of colours for free-standing sliding or tambour door units.

Cabinet variants



Combination and special cabinets

Recycling bins

Shelf with Orgaboxes



Wing door cabinet



Wing door cabinet with acoustical surface



Open shelves



Sliding door cabinet
with handle strip



Sliding door cabinet
with handle



Cabinet for suspended files



Tambour door unit
15 mm slat look



Tambour door unit
25 mm slat look



Aluminium frame door
with satin glass



Crystal fronts
(writeable)



Glass door

Lockable storage space

A variety of finishes and décors are available to customise the Allvia locker cabinets in three heights and five widths for the safe storage of personal belongings.



Closing mechanisms

The cabinets are offered with different locking systems.

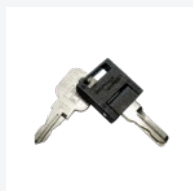

Keys
(optionally with individual lock systems)

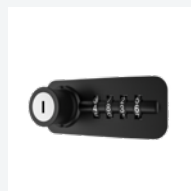

Numerical combination lock



Electronic lock
(RFID Mifare and Legic)



Smart process: Intelligent locker systems

Software-controlled locker systems enable the deposit of items or documents without being dependent on fixed times or personal contact. The smart system is truly versatile and can be used as bespoke storage space, as a temporary and limited solution for project groups, for smart goods issue, for staff and departments to hand over items or for the documented rental of technical equipment.



Digital solution: Smart locker systems



Log-in: RFID chip cards to open the lockers

System

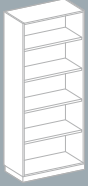

Filing shelves AR



Filing cabinets AT

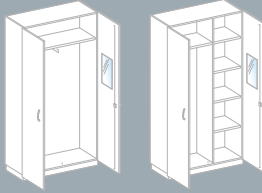

Wardrobe cabinets GT/GA



Tambour door units QSU/QSA



Special cabinets SB/PMA



Locker cabinets FD



Open filing shelves ABU/ABA

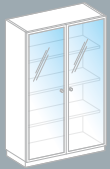

Display cabinets AT



Drawer cabinets AS
Cabinets for suspended files AS



Sliding door cabinets SHU/SHA



End corner shelves AE



Combination cabinets KS



Top-mounted shelves OR



Top-mounted cabinets OT

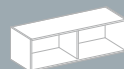

Wall shelves WR



Wall cabinets WT

Cabinet variants

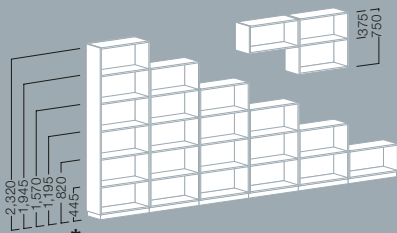

Filing shelves *

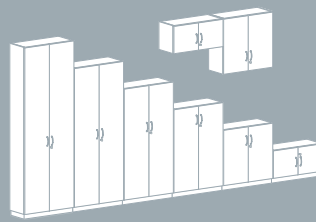

Filing cabinets

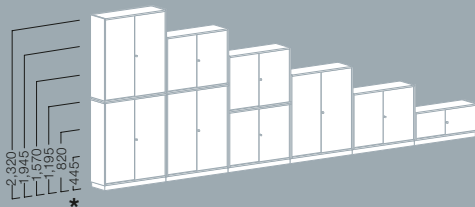

Sliding door cabinets *

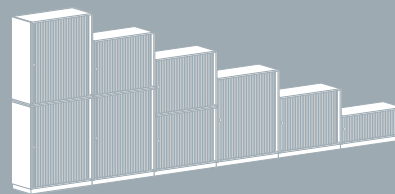

Tambour door units



Combination cabinets

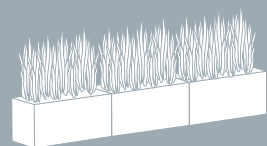

Plant pot mounts

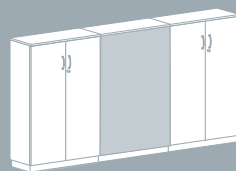

Fabric back walls

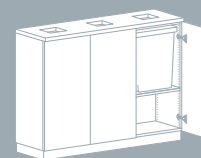

Recycling bins

Cubas



The partitioning Cubas shelf and storage space system combines innovative design with excellent functionality. Whether it's flexible storage space at the workplace, a bespoke room divider and hanging shelf or an attractive furnishing solution for your home office.



Learn more
<https://ass.al/siaa4sp>

Clever twist

Cubas comes with a unique and innovative rotation mechanism. The movable modules can be hand-rotated by 360° completely without tools in order to accommodate changing requirements and individual needs.





Eye-catcher

A multiple award winner, Cubas is the ideal furnishing solution for open-plan and modern working environments as well as in waiting areas and for your home office. The storage space system catches the eye with its excellent functionality and modern design that can be customised in a range of shapes and colours.



Working from home: Cubas as room partitions for home settings



Head-turner: Cubas adds colour to your waiting room



Creating highlights

Cubas is unbeatably versatile and can be combined with the Intavis and Allvia storage space systems. Highly variable, it catches the eye with its excellent functionality and is a perfect furnishing solution for working from home thanks to its appealing design.



Combinable: The Intavis and Cubas storage space systems



Versatile: Stylish wall shelf for your home office

Design variety

The purist design with its combination of metal frame and closed elements accommodates a wide range of looks and uses – whether as room partitions, wall shelves or sideboards.



Wide variety of design options

The bodies, functional shelves and swivel modules in the flexible Cubas furniture system can all be customised and combined with other storage space systems and even enable the addition of Allvia plant pot mounts.



Shelves

B: 440 mm / 880 mm



Metal shelves

B: 440 mm / 880 mm



Push to open

B: 440 mm / 880 mm



Tambour door units

B: 880 mm



Hinged cabinets

B: 880 mm



Wing-door cabinets/locker cabinets

B: 440 mm / 880 mm



Intavis



The Intavis design storage space system is synonymous with a minimalist and timeless look. The cabinet and shelving system is ideal for adding structure to open-plan offices and perfect for configuring open space work areas.

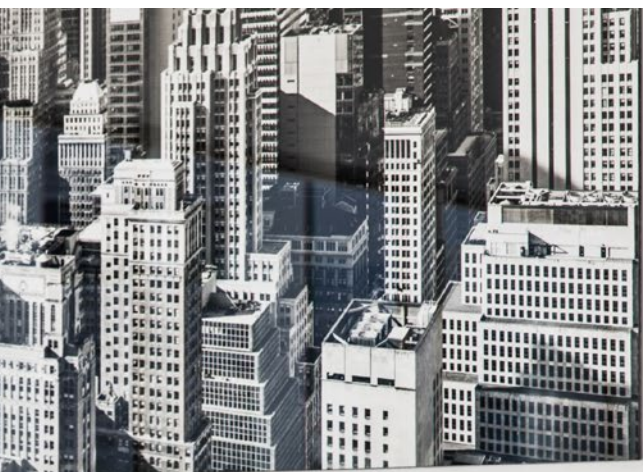

Learn more
<https://ass.al/pxygm10>

Handleless design

Intavis catches the eye not only with its handleless front, but also with a wide array of design options. Whether as a workplace storage space, a room partition in an open-plan office or as a wall shelf or wardrobe.



Versatile storage space concept

The Intavis storage space system comes with a wide variety of base designs.



Steel base
Height:
40 mm



Steel base
Height:
70 mm



Leg frame
Height:
100 mm



Telescope steel base
Height:
70 mm



Wide range of design options

The individual cabinet elements in the storage system can be combined individually to accommodate a broad variety of use cases.



Combination cabinets: Wide range of design options



Everything in its right place Attractive workplace storage space solution



Configuration options

The Intavis storage space system is an unbeatably versatile solution in modern design that can be combined optionally with the Cubas shelf system. With its attractive look, it offers more than just perfect furnishing for office workplaces and is equally ideal for working from home.



Combinable: Intavis and Cubas storage space systems



Versatile shelf system: Stylish and attractively designed

System

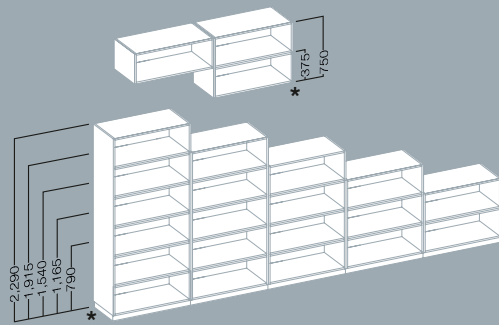

Filing shelves/wall shelves

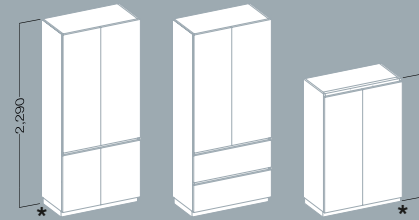

Wardrobes

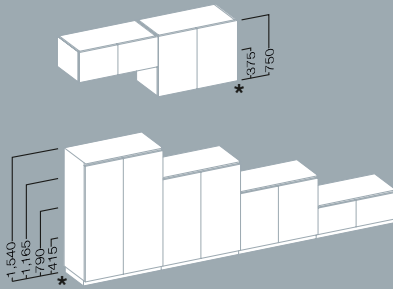

Filing cabinets / wall cabinets

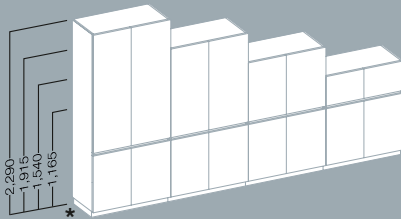

Combination cabinets

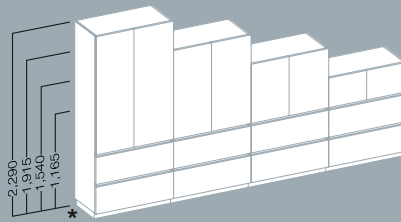

*Heights apply to units with a lower structure and base (40 mm)

All information is subject to change. Refer to the electronic planning data for information about the variants and sizes. All dimensions in mm.

Pontis



The practical and multifunctional furniture in the Pontis series creates tidy and optimally equipped workplaces. As individual added features, the storage solutions can also be used as extra work surfaces or to structure the room.



Learn more
<https://ass.al/leqz0rh>

Sufficient space

The versatile Pontis standing and rolling containers can be configured individually with different interior fittings and in different heights and depths.





All the documents and materials you routinely need are reliably on hand with the Pontis containers.



Addition for every workplace

The lockable open space containers provide practical storage space for work materials and personal belongings. At the same time, they also ensure privacy for undisturbed and concentrated work.





Mobile storage solutions for added flexibility

The Pontis mobile containers are fitted with castors, which makes them highly flexible and ideal furnishing solutions for desk sharing workplaces. The mobile storage solutions keep offices tidy and can be parked in container garages after use.





Improved order at the workplace

Pontis technical containers are predestined for storing technical equipment and frequently used materials directly at the workplace. Custom options are available for the function and design of the containers. Whether it is shelves, special pull-out elements, or fronts with handles and even without - Pontis has the right solution for every requirement.



Frame grommet for additional desk legroom



Versatile feature options

System



Roller containers



Caddies/mobile containers

Stand containers

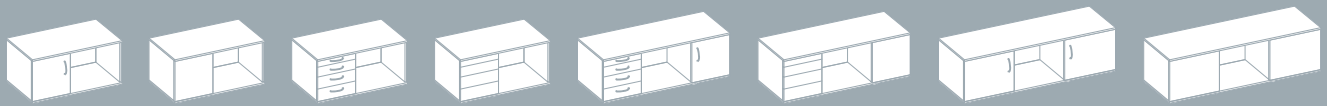

Technical containers

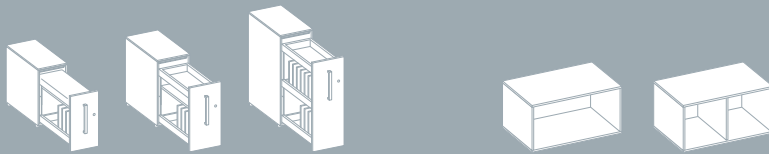

Open space containers

Open space container mounts



Caddy/mobile container garage



Mobile tambour door units



File trolleys

Container sets

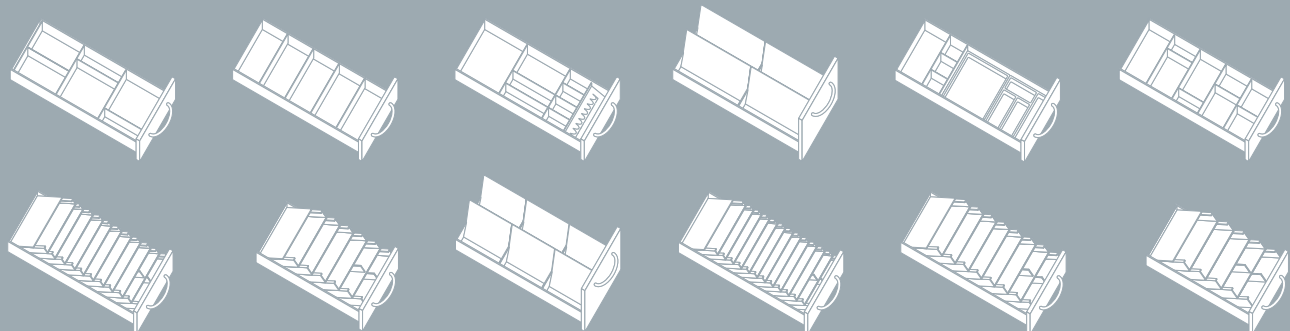

Handle variants

Handles



Curved handle



Railing handle



Elliptical handle



Flat handle



Linear handle



Trapezoid handle



Angled handle



Tambour door handle strip



Sliding door handle strip

Knobs



Knob 20



Knob 30



Rotating knob

Décor

BASIC Cubas | Allvia | Intavis | Pontis

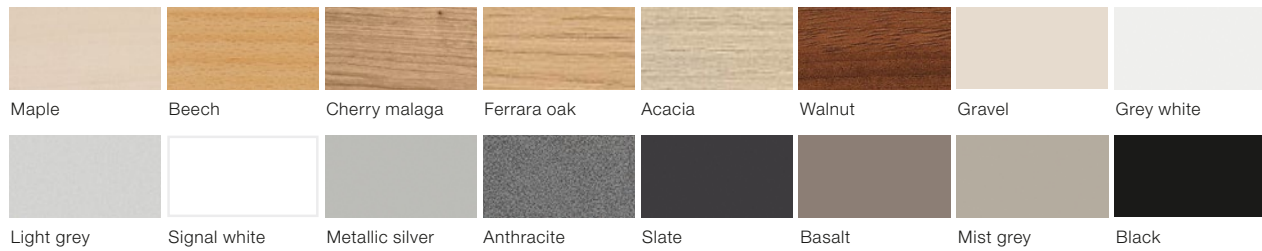

TREND Cubas | Allvia | Intavis

Panel thickness 19 mm for fronts and exposed back walls (not structural parts)

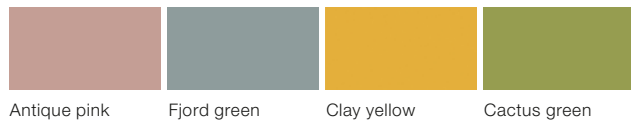

PREMIUM Cubas | Allvia | Intavis | Pontis

Panel thickness 19 mm and 25 mm for fronts, exposed back walls and side or top panels (not structural parts)

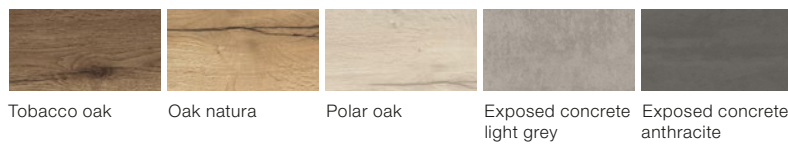

Veneers* Cubas | Allvia | Intavis | Pontis

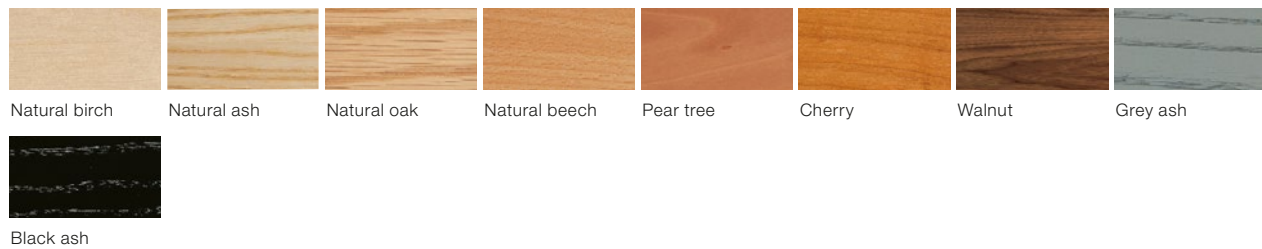

Base colours + frame colours Allvia | Intavis

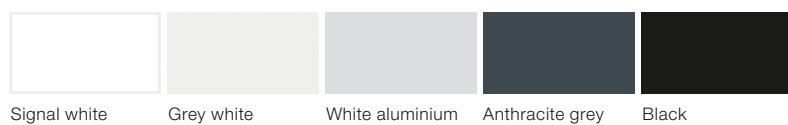

Glass laminate Allvia

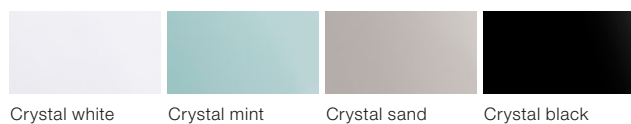

Acoustical surfaces Allvia

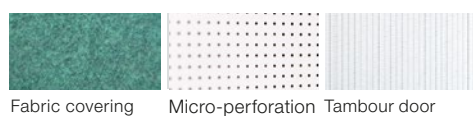

Tambour doors Allvia

Available in maple, beech, grey white, light grey, signal white, white aluminium, anthracite, slate.

* Other veneers on request



Award-winning GOOD WORK

We always adhere to the highest standards in our work – whether it's product quality, services or responsible treatment of the environment and natural resources. Along with the quality and safety certifications, our product and sustainability awards confirm that design, unbeatable quality and the use of harmless materials are indispensable attributes in the creation of modern worlds of work.



Furniture solutions and services from a single source

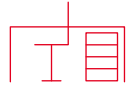

Desks

Modern design, a range of variants and tested quality, combined with optimised functionality and flexible height settings for ergonomic workspaces.

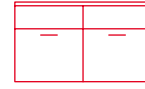

Storage space

Furnishing solutions for room design with functional storage space, modern wall shelves, secure locker cabinets and flexible container systems.

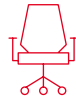

Office swivel chairs

Comfortable and ergonomic seating quality, attractive modern and clear design and easy handling with a wide choice of colours and surfaces.

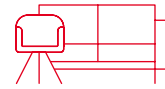

Seating

High-quality armchairs, comfortable sofas, modern and stackable multi-purpose chairs and freely combinable seating modules with optimised seating comfort and an unlimited range of colours and variants.



Lounge furniture

Open and closed room-in-room meeting and communication cubicles, flexible seating elements and comfortable lounge furniture in a variety of designs and surfaces.

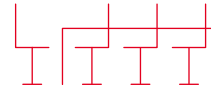

Seminars and meetings

Flexible and functional furnishing solutions for meetings, seminars and conferences with customisable versions and flexible combination options.

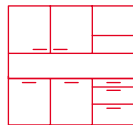

Office kitchens

Modern and high-quality kitchens with optimised functionality and plenty of storage space options, high-quality fittings and a wide range of design variants.



Reception

Modular, individually plannable reception and counter systems for designing the reception area with customisable surfaces and practical



Room acoustics

Acoustically effective furnishing solutions with attractive finishing, matching components and partitioning screen systems to improve room acoustics.

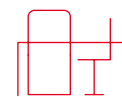

Components

Innovative docking systems, multifunctional organisational rails and partition wall systems for acoustic and hygiene requirements in a variety of designs and surfaces.



Booking systems

Smart office solutions for organising office workspaces based on sensor-supported booking systems and software-controlled locker systems.



Services

End-to-end consulting and planning services to design and create modern worlds of work with additional pre- and after-sales support.

ASSMANN BÜROMÖBEL GMBH & CO. KG

Heinrich-Assmann-Straße 11
D-49324 Melle

P.O. Box 1420
D-49304 Melle

Fon +49 (0) 5422 706-0

info@assmann.de
www.assmann.de

ASSMANN