

PRO WAVE

Perfect Resource - Optimised Bin

ssi-schaefer.com



SSI SCHÄFER

PRO WAVE

Perfect Resource - Optimised Bin

- Made of High Density Polyethylene, HDPE
- Resource optimised containers for waste and recycling materials in the patented Wave design
- State of the art production methods using minimum raw materials
- Ergonomic handling
- High stability



TECHNOLOGY AND INNOVATION

- The latest production methods and state of the art injection moulding machines enable production of pioneering innovative products.
- The manufacturing methods and machinery have made it possible to produce one of the lightest two wheeled containers on the market.
- Despite the low body weight, the container has high stability caused due to the production process.
- The innovative multiple injection system used in the production process enables injection of the plastic material at significantly more points of the container tool, providing a reduced wall thickness with even and stress free material distribution.



PRO Wave 240 l, 120 l, 80 l, 60 l



Computer simulation of drop test

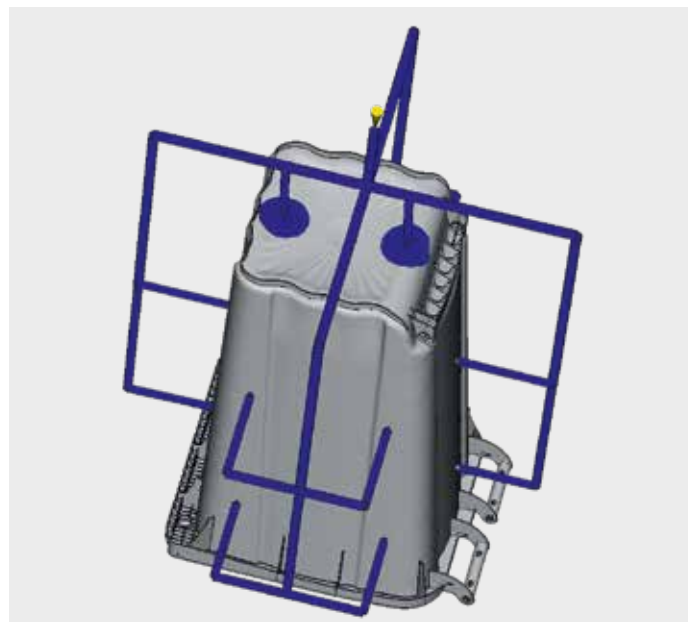

Innovative multi injection frame

PROTECTION OF RESOURCES

- The sustainable business strategy is protection of the environment, resource conservation and reduction of CO2 emissions.
- The focus is on environmentally friendly production ensuring our products have the lowest possible environmental impact of our products.
- An optimized production is achieved by using reground material from end of life containers.
- The most efficient conservation of resources is to keep the input of raw materials to an absolute minimum as demonstrated by the exemplary success of the PRO Wave.

DESIGN AND ERGONOMICS

- High stability and unique Wave look
- Optimum handling with the ergonomic concept
- Practical foothold as well as low bin weight
- The low weight of the bins protects collection operatives health and increases efficiency and sustainability
- The reduced weight on the lifting gear decreases the fuel consumption of the vehicle as well as the wear and tear on the lifter.



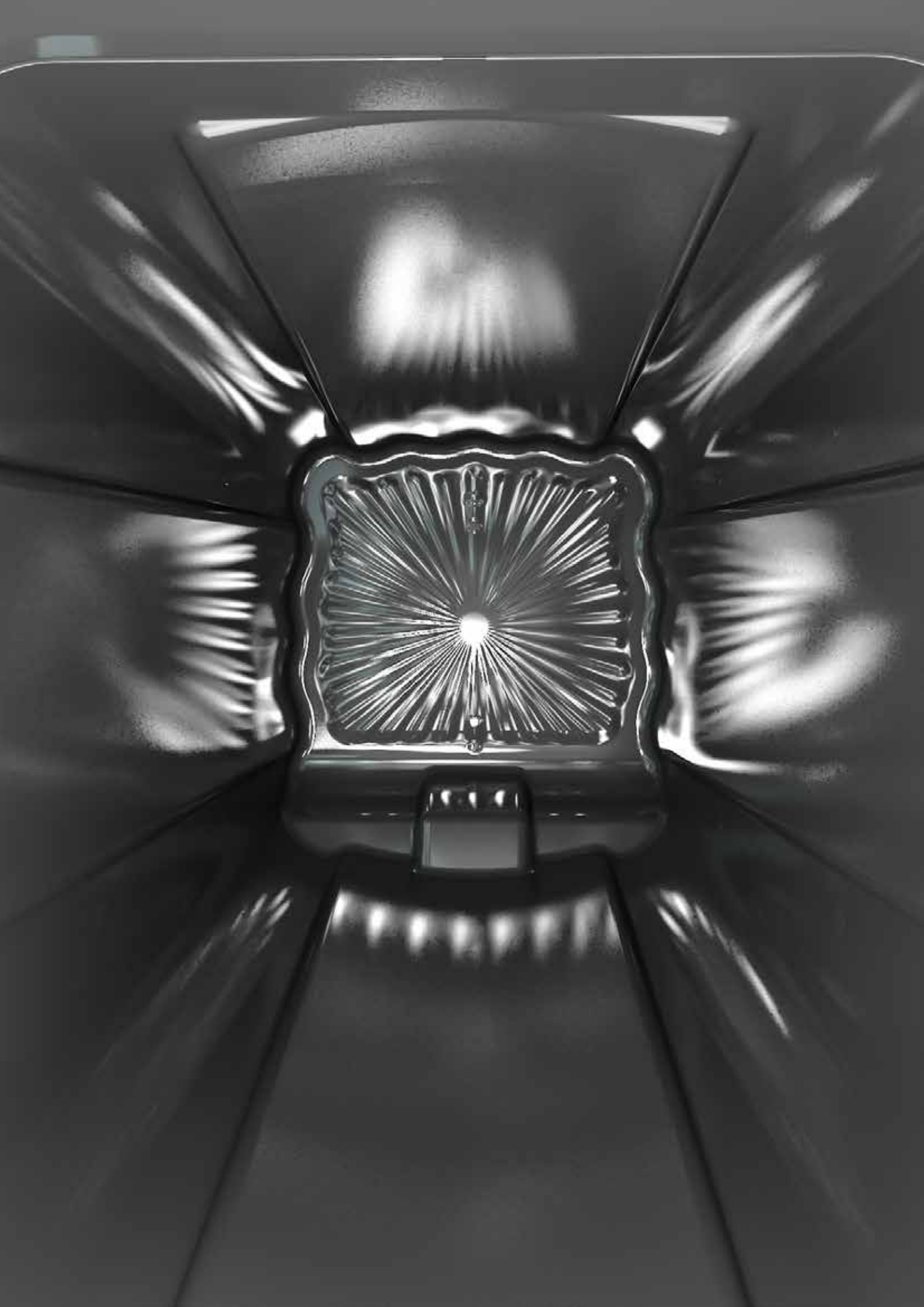

PRO WAVE 60 - 240 LITRES

- Available in 80 l, 120 l und 240 l
- Made of High Density Polyethylene, HDPE
- UV-stabilised
- Ergonomic design of the lid handles
- Lid with all-round drip rib for condensation water
- Manufactured according to DIN EN 840 - 1, 5 und 6
- RAL quality tested
- Axles from hardened and tempered steel
- Integrated chip-nest for transponder
- External gear for high stability
- Cushioning of the impact by the open lid on the body according to EU directive 2000/14/EG

Pro Wave	60 l	80 l	120 l	240 l
Width mm (W)	446	448 ± 5	480 ± 5	585
Height mm (H)	922	932 max.	1.005 max.	1.100 max.
Depth mm (D)	514	514 max.	555 max.	740 max.
Nominal volume l	60 +13 / -5	80 + 18 / -5	120 + 8 / -6	240 - 15 / -5
Payload kg	40	40	48	96
Wheel - Ø mm	200	200	200	200

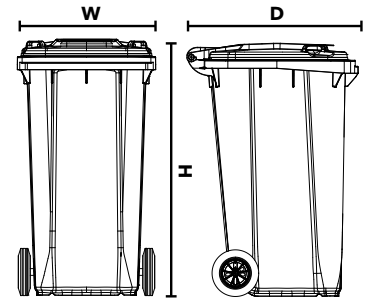

All dimensions are nominal in accordance with DIN EN 840.



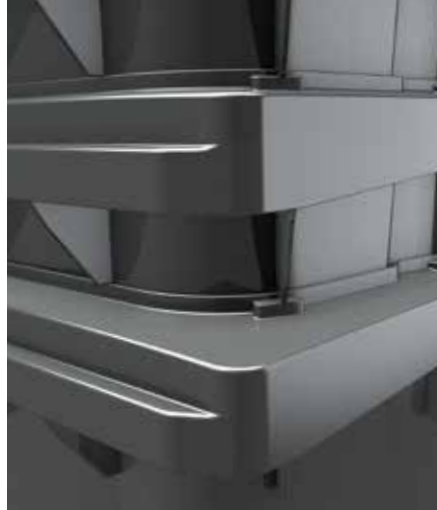

Perfect Optimisation Of Resources

- Optimized use of raw materials
- Highest material quality
- Reduced CO2 emissions
- Latest injection molding machines
- Sustainable production process with state-of-the-art technology
- Most innovative tool generation with multiple injection

Economics

- High stacking for cost-effective transports
- Space saving storage
- Low bin weight
 - Less wear and fuel consumption for the collection vehicle
- Protection of health
- Promotes productivity
- Ergonomic handling

Proven SSI SCHAEFER Quality

- RAL quality tested
- Increased container strength
 - Special base design
 - Continuous wave contour
 - Fully profiled side walls
- Stress free material distribution
- Robust stacking supports



Continuous handle tube with 2 point hinges



Lid with 4 point hinges



Integrated foothold

Standard bin colours PRO Wave 80, 120 und 240 Litres

Rape yellow RAL 1021	Red RAL-Design 040 40 67	Blue RAL-Design 270 40 40
Black grey RAL 7021	Pale brown RAL 8025	Green RAL-Design 150 40 20 (140 40 20)

Standard bin colours PRO Wave 60 Litres

Black grey RAL 7021	Pale brown RAL 8025	Green RAL-Design 150 40 20 (140 40 20)
------------------------	------------------------	---

More colours on request.

SIX REASONS FOR CHOOSING SSI SCHAEFER

- **Stability**

As a financially independent family business, SSI SCHAEFER is committed to long-term solutions. You can trust that our team of experts will be there for you today, tomorrow and in years to come.

- **Efficiency**

SSI SCHAEFER solutions are expandable and grow with your business. The modular structure of the solutions allows you to upgrade or modernize your processes step by step at any time.

- **Quality**

As a recycling industry expert with in-house development and production, SSI SCHAEFER provides an array of high-quality solutions from a single source. Targeted quality management according to established standards guarantees high reliability and durability of our products - this is also certified by independent authorities.

- **Reliability**

Thanks to our own Customer Service & Support, SSI SCHAEFER ensures smooth operation of your systems and processes, both during and after implementation.

- **Know-how**

For decades, SSI SCHAEFER has been trendsetting in the development of novel disposal systems and sets new standards in waste management with innovations and high quality.

- **Digitalization**

SSI SCHAEFER solutions are always up-to-date with the latest technology. Our digital experts design comprehensive, needs-oriented system solutions and modular concepts that integrate seamlessly into your existing structures and generate direct added value.

[ssi-schaefer.com](https://www.ssi-schaefer.com)

2021/04 EN © SSI SCHÄFER
Printed in Germany.

We assume no responsibility for printing errors. This catalogue is supplied E&OE.



SSI SCHAEFER