

PRODUCTS

ENGLISH

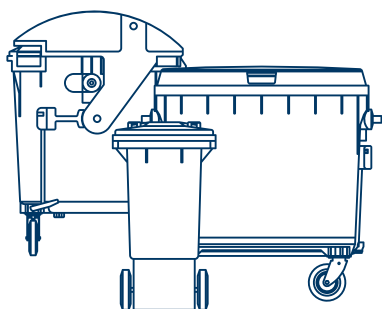

W-weber
www.w-weber.com



ABFALLBEHAELTER & CONTAINER WEBER GmbH & Co. KG

quality made in germany



Weber is one of the leading manufacturers of waste management products and offers a high-quality range of waste containers and litter bins. All Weber products are manufactured exclusively in Haan, Germany using the compact injection moulding process.

Weber containers are the perfect solution for all types of waste and recyclable materials, such as residual waste, paper, glass, packaging etc. and are available in a variety of standard sizes and designs.

Our modern production facilities, combined with continuous internal quality controls and current external inspections by independent testing institutes, guarantee products of the highest quality.

Weber is your reliable partner for the waste management industry!



ABFALLBEHAELTER & CONTAINER WEBER GmbH & Co. KG
BERGISCHE STRASSE 10-14, D-42781 HAAN, GERMANY
Tel.: + 49 2129 93 62 - 0 • Fax: + 49 2129 93 62 - 22
info@w-weber.com

WEBER WASTE BINS

WEBER MINI WASTE BIN 0.4 LITRE MINIATURE - MGB OF 240L BIN

Nominal volume: 0.4 l

Empty weight: 59 g

Dimensions (W/D/H): 73 x 93 x 136 mm

- accurate copy of our MGB 240 litre
- UV, cold, heat and chemical resistant
- manufactured from high-quality virgin material using the injection moulding process
- material free of harmful substances
- ideal promotional gift for your customers, individually printable body
- can be used to store pens, packed sweets or small change
- is suitable for dealing with all topics related to waste advice, e.g. the topic of waste separation can be explained in a playful way
- available in green, red, yellow, blue, brown, grey - other colours on request



WASTE BIN 10 LITRE PRESORTING CONTAINER

Nominal Volume: 10 l

Empty weight: 500 g

Dimensions (W/D/H): 208 x 279 x 309 mm

- manufactured from HDPE using the compact injection moulding method
- resistant to UV, cold, heat and chemicals
- galvanised steel wire folding handle
- standard markings on the lid: neutral or Weber
- available in brown and green - other colours on request



WASTE BIN 50 LITRE IN ACCORDANCE WITH DIN 30713

Nominal Volume: 50 l

Empty weight: 4.0 kg

Dimensions (W/D/H): 432 x 334 x 745 mm

- manufactured from HDPE using the compact injection moulding method in accordance with DIN 30713
- resistant to UV, cold, heat and chemicals
- easily mounted on posts, trellises and walls
- body can be emptied or exchanged by simple release with a triangular key
- cigarette stubber made of stainless steel
- galvanised metal parts
- available in standard orange (RAL 2010) and green (RAL 6011) - other colours on request



2-WHEELED BINS WEBER MGB 240L IN ACCORDANCE WITH EN 840



THE MOST POPULAR SIZE
BY OPTIMAL VOLUME

- // SOLID LID
- // STABLE FULL-LENGTH HANDLE
- // ERGONOMIC CHASSIS



MGB 60L / 80L / 120L / 140L / 180L / 240L / 360L WEBER 2-WHEELED BINS IN ACCORDANCE WITH EN 840

- Weber 2-wheeled MGB manufactured from HDPE using the compact injection moulding method in accordance with EN 840-1
- resistant to UV, cold, heat and chemicals
- galvanised steel axle (corrosion resistant)
- standard wheels with solid rubber tyres Ø 200 x 50 mm carrying capacity 100kg/wheel – other options available
- MGB 140, 180, 240 L with optional Ø 250 mm wheels and MGB 360 L with optional Ø 300 mm wheels
- chip-nest according to DIN 30745:2014 and RAL GZ 951/1
- standard colours grey, green, blue and brown – other colours available on request



WEBER 2-WHEELED MGB	60L	80L	120L	140L	180L	240L	360L
Nominal volume (l)	60	80	120	140	180	240	360
Nominal payload (kg)	40	40	48	56	72	96	144
Empty weight ca. (kg)	8,5	8,5	8,2	10,0	11,0	11,7	18,9
A Lid, width (mm)	421	421	440	440	440	533	580
B Wheel Ø (mm)	200	200	200	200/250	200/250	200/250	200/300
C Travelling gear, width (mm)	445	445	490	480	485	575	578
D Body, height (mm)	884	881	868	995	997	985	1005
E Total height (mm)	935	939	930	1050	1063	1067	1098
F Total depth (mm)	520	520	550	550	712	720	878
G Total width (mm)	445	445	475	478	477	576	596
K Customer field 197 x 30 mm for all 2-wheeled bins (customer name or blank)							

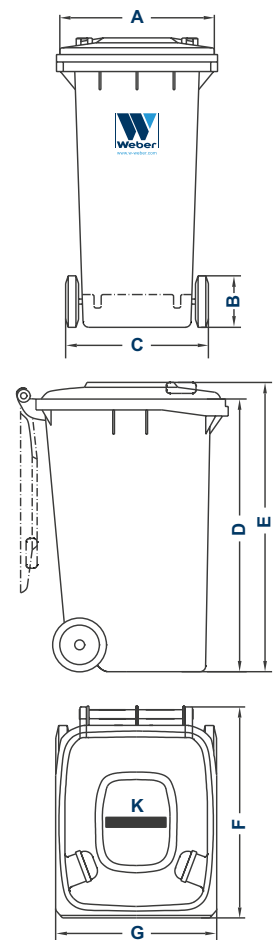

We reserve the right to make dimensional and constructional alterations



4-WHEELED BINS MGB 1100L FLAT LID

CLASSIC (FL C) IN ACCORDANCE WITH EN 840



VERY ROBUST PERFORMANCE
SEPARATE HINGE FIXINGS

- // INCREASED WALL THICKNESS
- // HINGE FIXINGS
- // INTEGRATED CHIP-NEST



WEBER MGB 660L / 770L / 1100L / 1100L C FLAT LID (FL) IN ACCORDANCE WITH EN 840

- Weber MGB manufactured from HDPE using the compact injection moulding method in accordance with EN 840
- bins can be easily repaired
- chip-nest for secure transponder placement
- galvanised metal parts (corrosion resistant)
- resistant to UV, cold, heat and chemicals
- optionally with lifting trunnions
- standard colours grey, green, blue and brown – other colours available on request

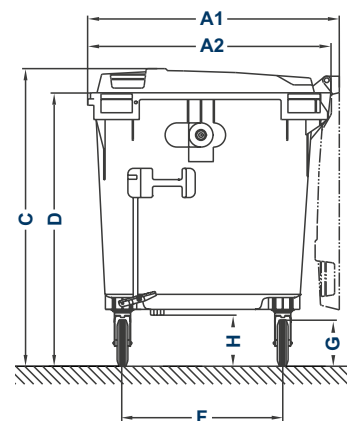
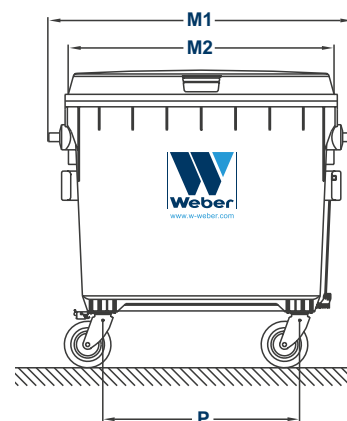

WEBER 4-WHEELED MGB FLAT LID (FL)	660L	770L	1100L FL	1100L FL C
Nominal volume (l)	660	770	1100	1100
Nominal payload (kg)	270	310	440	440
Empty weight ca. (kg)	37,6	41,0	47,4	52,6
A1 Total depth, lid open (mm)	778	791	1085	1113
A2 Body, total depth (mm)	772	779	1065	1085
C Total height (mm)	1230	1316	1330	1309
D Body, height (mm)	1145	1235	1205	1212
P/F Travelling gear, width (mm)	845/480	840/485	855/755	855/745
G Wheel Ø (mm)	160/200	160/200	200	200
H Ground clearance (mm)	190	190	200	225
M1 Width with lifting trunnions (mm)	1371	1371	1375	1371
M2 Lid, width (mm)	1134	1134	1180	1168

Customer field 370 x 49 mm for all 4-wheeled bins (customer name or blank)



We reserve the right to make dimensional and constructional alterations

4-WHEELED BINS MGB 1100L FLAT LID

LID IN LID (FL LIL) IN ACCORDANCE WITH EN 840



EASY FILLING
THROUGH LIGHTWEIGHT SMALLER LID

- // LID IN LID
- // EASY FILLING
- // WIDE APERTURE



WEBER MGB 660L / 770L / 1100L FLAT LID, LID IN LID (FL LIL) IN ACCORDANCE WITH EN 840

- Weber MGB manufactured from HDPE using the compact injection moulding method in accordance with EN 840-2
- simple exchange of the main lid and smaller lid
- stepped rim, reinforced by additional ribbing
- chip-nest for secure transponder placement
- galvanised metal parts (corrosion resistant)
- resistant to UV, cold, heat and chemicals
- optionally with lifting trunnions
- standard colours grey, green, blue and brown – other colours available on request

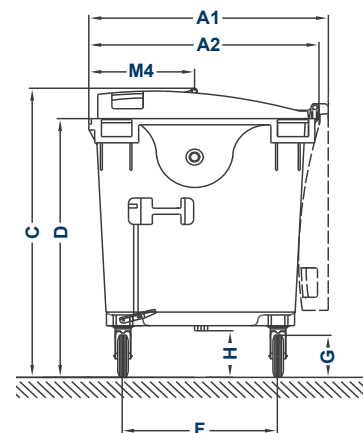
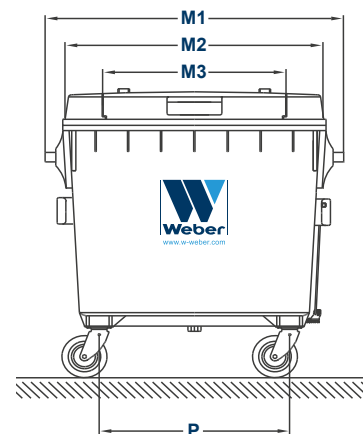

WEBER 4-WHEELED MGB FLAT LID (FL LIL)	660L FL LIL	770L FL LIL	1100L FL LIL
Nominal volume (l)	660	770	1100
Nominal payload (kg)	270	310	440
Empty weight ca. (kg)	38,0	41,4	48,4
A1 Total depth, lid open (mm)	845	840	1085
A2 Body, total depth (mm)	772	779	1065
C Total height (mm)	1265	1345	1340
D Body, height (mm)	1145	1235	1205
P/F Travelling gear, width (mm)	845/480	840/485	855/755
G Wheel Ø (mm)	160/200	160/200	200
H Ground clearance (mm)	190	190	200
M1 Width with lifting trunnions (mm)	1371	1371	1375
M2 Lid, width (mm)	1134	1134	1180
M3 Lid in lid, width / aperture (mm)	775/710	775/710	840/760
M4 Lid in lid, depth (mm)	375	375	430

Customer field 370 x 49 mm for all 4-wheeled bins
(customer name or blank)

We reserve the right to make dimensional and constructional alterations.



4-WHEELED BINS MGB 1100L ROUND LID

LID IN LID (RL LIL) IN ACCORDANCE WITH EN 840



EASY FILLING
THROUGH LIGHTWEIGHT SMALLER LID

- // LID IN LID
- // EASY FILLING
- // WIDE APERTURE



WEBER MGB 1100L RL / 1100L RL LIL ROUND LID, LID IN LID (RL LIL) IN ACCORDANCE WITH EN 840

- Weber MGB manufactured from HDPE using the compact injection moulding method in accordance with EN 840-3
- sliding lid can be secured in three positions
- all models with child safety device according to EN 840-6
- 1100L RL LIL is equipped with an easily exchangeable, smaller lid
- stepped rim, reinforced by additional ribbing
- chip-nest according to RAL-GZ 951/1 for secure transponder placement
- galvanised metal parts (corrosion resistant)
- 200 mm diameter quiet-running, solid rubber castors with 360° swivel range
- resistant to UV, cold, heat and chemicals
- standard colours grey, green, blue and brown – other colours available on request

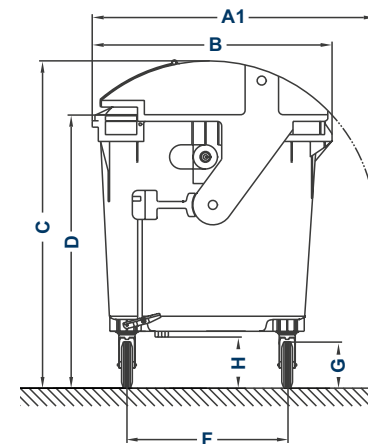
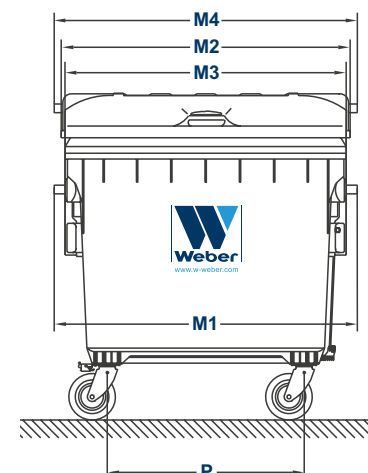

WEBER 4-WHEELED MGB ROUND LID (RL)	1100L RL	1100L RL LIL
Nominal volume (l)	1100	1100
Nominal payload (kg)	440	440
Empty weight ca. (kg)	62,2	61,0
A1 Total depth, lid open (mm)	1220	1220
B Body, total depth (mm)	1065	1065
C Total height (mm)	1460	1460
D Body, height (mm)	1205	1205
P/F Travelling gear, width (mm)	855/745	855/745
G Wheel Ø (mm)	200	200
H Ground clearance (mm)	225	225
M1 Width with lifting trunnions (mm)	1372	1372
M2 Lid, width (mm)	1270	1270
M3 Body, width (mm)	1200	1200
M4 Width with lid trunnions (mm)	1370	1370

Customer field 370 x 49 mm for all 4-wheeled bins
(customer name or blank)

We reserve the right to make dimensional and constructional alterations.



CLINICAL WASTE CONTAINERS

WEBER MGB 770L

IN ACCORDANCE WITH EN 840 / UN-CODE 3291



CLINICAL WASTE
SAFE COLLECTION AND TRANSPORTATION

- // SOLID STRIKER PLATE
- // TRIANGULAR SLAM LOCK
- // WATERTIGHT



MGB 240L / 360L / 660L / 770L / 1100L C CLINICAL WASTE CONTAINERS IN ACCORDANCE WITH EN 840 / UN-CODE 3291

- certified Weber Clinical Waste Containers 240, 360, 660, 770 and 1100 litre, made from HDPE in accordance with EN 840
- resistant to UV, cold, heat and chemicals
- UN-certified for collection of dangerous material
- watertight (without drainage hole)
- with triangular slam lock
- packing groups II and III with UN-marking 50H/Y
- marked for bio medical and clinical waste in accordance with UN3291

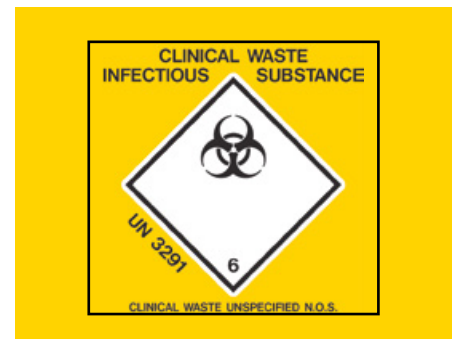

WEBER 2-WHEELED / 4-WHEELED MGB	240L	360L	660L	770L	1100L C
Nominal volume (l)	240	360	660	770	1100
Nominal payload (kg)	96	144	270	310	440
Empty weight ca. (kg)	11,7	18,9	37,6	41,0	52,6
Total height (mm)	1067	1098	1230	1316	1309
Body, height (mm)	985	1005	1145	1235	1212
Total depth, lid open (mm)	720	878	778	791	1113
Body, total depth with hinges (mm)			772	779	1085
Total width (mm)	576	596	1212	1213	1205
Lid, width (mm)	533	580	1134	1134	1168
Travelling gear, width (mm)	575	578	480	485	745
Wheel Ø (mm)	200/250	200/300	160/200	160/200	200
Ground clearance (mm)			190	190	225

Customer field 197 x 30 mm for all 2-wheeled bins (customer name or blank)
Customer field 370 x 49 mm for all 4-wheeled bins (customer name or blank)



We reserve the right to make dimensional and constructional alterations.



OPTIONAL EQUIPMENT WEBER 2- AND 4-WHEELED BINS

Weber Wheeled Bins			No.	60L/80L	120L
Lid apertures	for bottles	one aperture with/without rubber collar two apertures with/without rubber collar		•	•
	for paper	paper slot 300 x 20 mm with/without canopy	7	•	•
Lock systems	for packaging	with/without brushes			
	triangular lock		9	•	•
	gravity lock		2 8	•	•
Lid opener	mounting device for padlock			•	•
	with foot pedal		11		•
Lifting handles	side mounted (right and left) - included with central brake		10		
Handles	full-length			Standard	Standard
Hinge fixings	moulded			Standard	Standard
	screwed				
Lifting devices	comb lifting			Standard	Standard
	DIN lifting		5		
	DIN lifting with safety stopper		6		
Travelling gear	Ochsner-type handles				
	central brake with lifting handle		10		
	directional lock (x2)				
Bin markings	wheel brake on front wheels (x2)				
	embossing on lid			•	•
Wheels	hot-foil printing on body and lid		1 3	•	•
	Ø 160 mm				
	Ø 200 mm			Standard	Standard
	Ø 250 mm				
	Ø 300 mm				
	heavy duty wheels with ball-bearing				
	non-marking wheels				
Noise reduction (lid)				•	•
Chip-nest for secure transponder placement			4	Standard	Standard
Towing kit			12		
Fork lift pockets					
4-wheeled body without drainage hole					
Clamping ring for plastic bags					•





ABFALLBEHAELTER & CONTAINER WEBER GmbH & Co. KG
BERGISCHE STRASSE 10-14, D-42781 HAAN, GERMANY
Tel.: + 49 2129 93 62 - 0 • Fax: + 49 2129 93 62 - 22
info@w-weber.com

english

www.w-weber.com